

**HEATHKIT**  
**MODEL IM-21**  
**VTVM**

Assembly  
and  
Operation  
of the



# VACUUM TUBE VOLTMETER

MODEL IM-21

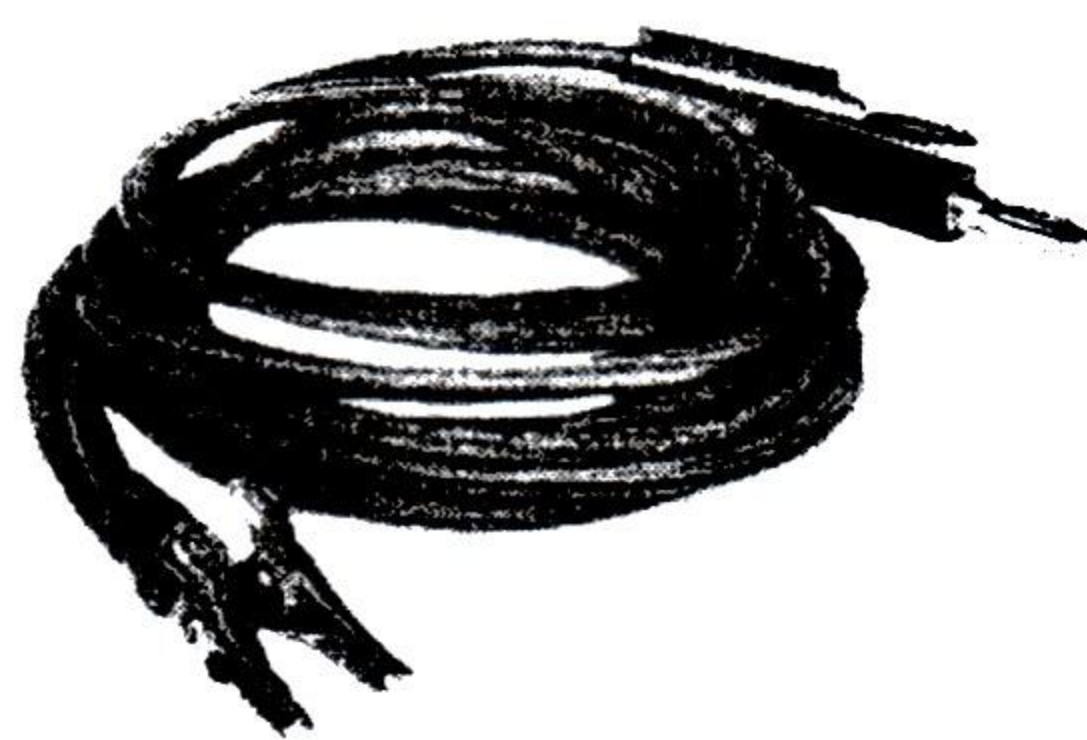
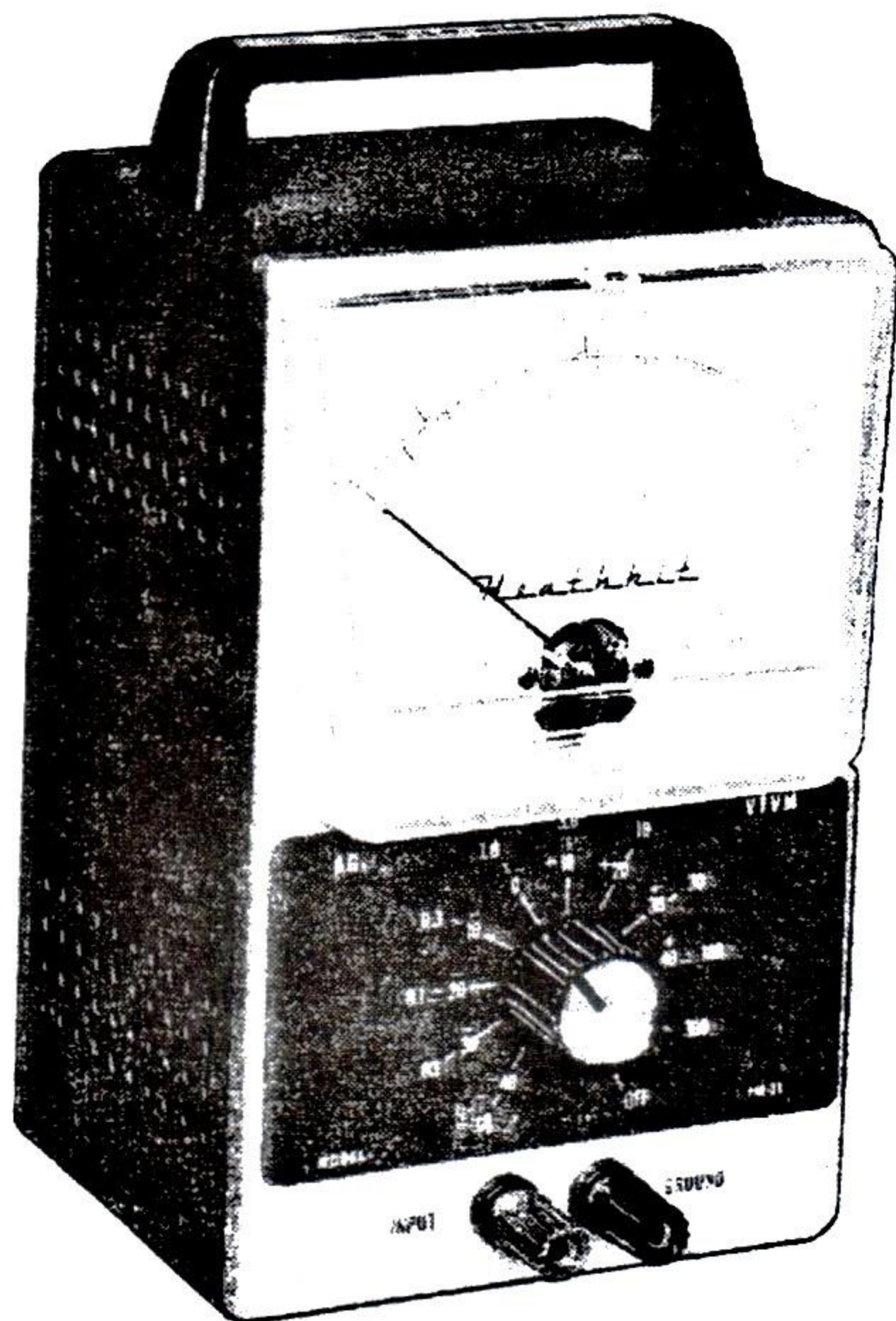

HEATH COMPANY  
BENTON HARBOR,  
MICHIGAN

## TABLE OF CONTENTS

Specifications. . . . .	2
Introduction. . . . .	2
Circuit Description. . . . .	3
Construction Notes. . . . .	3
Parts List. . . . .	4
Proper Soldering Techniques. . . . .	7
Step-By-Step Procedure. . . . .	8
Step-By-Step Assembly. . . . .	9
Range Switch Wiring. . . . .	10
Top Chassis Wiring. . . . .	12
Wiring The Bottom Chassis. . . . .	14
Final Wiring And Assembly. . . . .	18
Adjustments. . . . .	20
Operation. . . . .	21
Applications. . . . .	21
Bibliography. . . . .	22
In Case Of Difficulty. . . . .	22
Service Information. . . . .	23
Service. . . . .	23
Replacements. . . . .	24
Shipping Instructions. . . . .	24
Warranty. . . . .	25
Schematic. . . (fold-out from Page). . . . .	25
Replacement Parts Price List. . . . .	26

The Heath Company reserves the right to discontinue instruments and to change specifications at any time without incurring any obligation to incorporate new features in instruments previously sold.

## SPECIFICATIONS

Frequency Response. . . . .	$\pm 1$ db from 10 cps to 500 kc, all ranges. $\pm 2$ db from 10 cps to 1 mc, all ranges.
Ranges. . . . .	Ten ranges, marked both in volts and db.
Volts. . . . .	.01, .03, .1, .3, 1, 3, 10, 30, 100, 300 volts rms full scale.
Decibels. . . . .	-40, -30, -20, -10, 0, +10, +20, +30, +40, +50 db (0 db is equal to 1 milliwatt in 600 $\Omega$ ).
Input Impedance. . . . .	10 megohms shunted by 12 $\mu\mu\text{f}$ on all ranges from 10 volts to 300 volts.  10 megohms shunted by 22 $\mu\mu\text{f}$ on all ranges from .01 volt to 3 volts.
Power Requirements. . . . .	105-125 volts, 50/60 cps AC, 10 watts.
Dimensions. . . . .	7-3/8" high x 4-11/16" wide x 4-1/8" deep.
Accuracy. . . . .	Within 5% of full scale.
Net Weight. . . . .	3 lbs.

## INTRODUCTION

The Model IM-21 Vacuum Tube Voltmeter is designed to measure AC voltages from 10 cycles per second to 1 megacycle. These AC voltages can be read on 10 ranges; the 10 millivolt range is lowest and the 300 volt range is highest. Each of these ten ranges is also calibrated in decibels (db) for your convenience.

A high input impedance (10 megohms) is provided

so that the VTVM can be used to measure voltages in sensitive circuits without appreciable loading.

The VTVM normally is used to indicate steady AC voltages. It can also be used like a VU meter to indicate changing AC voltages, such as found in speech or music equipment. (The VU meter is a standard level meter used in the broadcasting and recording fields.)

## CIRCUIT DESCRIPTION

It may be helpful to refer to the Schematic Diagram while reading the following description.

The circuit of this VTVM may be divided into four general sections: The input section, which consists of the input cathode follower and the input attenuators; the amplifier section; the meter circuit; and the power supply.

The input AC voltage is first applied to the frequency-compensated, 1000-to-1 voltage divider in the grid circuit of input cathode follower V1A. Input voltages for the lower six ranges are coupled directly to the grid of V1A from the top of the voltage divider. Input signals for the higher four ranges are divided by 1000 and coupled to the grid of V1A from the lower tap of the voltage divider.

The cathode follower stage, V1A, represents a high impedance to the input signal applied to its grid. The output of V1A is a low impedance source for the signal applied to the precision voltage divider which feeds the input of the amplifier section.

The precision voltage divider divides the signal from the cathode follower into the six dif-

ferent levels to provide ten scales, with readings from 10 millivolts to 300 volts.

The amplifier section consists of V1B, V2, and the various circuit components in these two stages. Approximately 19 db of negative feedback is returned through the meter circuit from V2 to the cathode circuit of V1B. This negative feedback provides high stability and uniform gain over the wide frequency range of the amplifier.

The meter circuit consists of a 200 micro-ampere meter, with a full-wave bridge rectifier that uses four germanium diodes. For calibration purposes, the amount of meter current can be adjusted by means of the calibrate control. This control determines the amount of meter current by adjusting the amount of negative feedback to the cathode of V1B.

The power supply consists of a half-wave rectifier circuit, containing a silicon rectifier and capacitor C17. The power supply also supplies filament voltage to the tubes and pilot lamp. In order to minimize hum, the filament winding of the power transformer is balanced to ground through resistors R28 and R29.

## CONSTRUCTION NOTES

This manual is supplied to assist you in every way to complete your kit with the least possible chance for error. The arrangement shown is the result of extensive experimentation and trial. If followed carefully, the result will be a stable instrument, operating at a high degree of dependability. We suggest that you retain the manual in your files for future reference, both in the use of the instrument and for its maintenance.

**UNPACK THE KIT CAREFULLY AND CHECK EACH PART AGAINST THE PARTS LIST.** In so doing, you will become acquainted with the parts.

Refer to the charts and other information on the inside covers of the manual to help you identify the components. If some shortage or parts damage is found in checking the Parts List, please read the Replacement section and supply the information called for therein.

Resistors generally have a tolerance rating of 10% unless otherwise stated in the Parts List. Tolerances on capacitors are generally even greater. Limits of +100% and -20% are common for electrolytic capacitors.

We suggest that you do the following before work is started:

1. Lay out all parts so that they are readily available.
2. Provide yourself with good quality tools. Basic tool requirements consist of a screwdriver with a 1/4" blade; a small screwdriver with a 1/8" blade; long-nose pliers; wire cutters, preferably separate diagonal cutters; a pen knife or a tool for stripping insulation from wires; a soldering iron (or gun) and rosin core solder. A set of nut drivers and a nut starter, while not necessary, will aid extensively in construction of the kit.

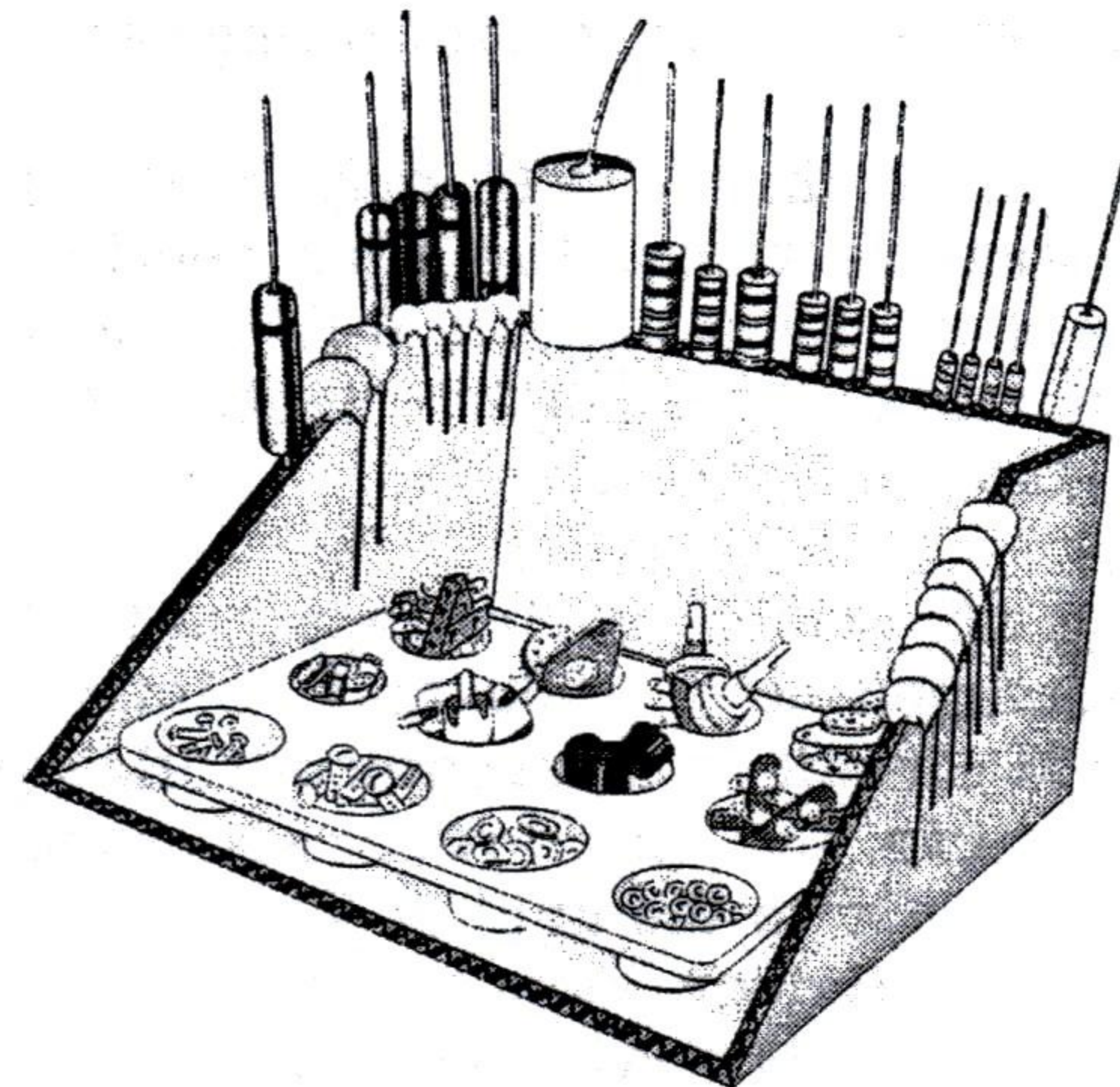

Most kit builders find it helpful to separate the various parts into convenient categories. Muffin tins or molded egg cartons make convenient trays for small parts. Resistors and capacitors may be placed with their lead ends in-

serted in the edge of a piece of corrugated cardboard until they are needed. Values can be written on the cardboard next to each component. The illustration shows one method that may be used.

## PARTS LIST

<u>PART No.</u>	<u>PARTS Per Kit</u>	<u>DESCRIPTION</u>
<u>Resistors</u>		
① 1-49	1	22 Ω 1/2 watt (red-red-black)
1-103	1	33 Ω 1/2 watt (orange-orange-black)
1-1	3	47 Ω 1/2 watt (yellow-violet-black)
1-118	1	82 Ω 1/2 watt (gray-red-black)
1-3	2	100 Ω 1/2 watt (brown-black-brown)
1-13	1	2700 Ω 1/2 watt (red-violet-red)
1-20	2	10 KΩ 1/2 watt (brown-black-orange)
1-25	3	47 KΩ 1/2 watt (yellow-violet-orange)
1-60	1	68 KΩ 1/2 watt (blue-gray-orange)
1-27	1	150 KΩ 1/2 watt (brown-green-yellow)
1-33	4	470 KΩ 1/2 watt (yellow-violet-yellow)

<u>PART No.</u>	<u>PARTS Per Kit</u>	<u>DESCRIPTION</u>
<u>Resistors (cont'd.)</u>		
② 2-159	1	100 Ω precision
2-25	1	216.2 Ω precision
2-28	1	683.8 Ω precision
2-31	1	2162 Ω precision
2-33	1	6838 Ω precision
2-39	1	21.62 KΩ precision
2-17	1	10 megohm precision
③ 2-50	1	10 KΩ precision

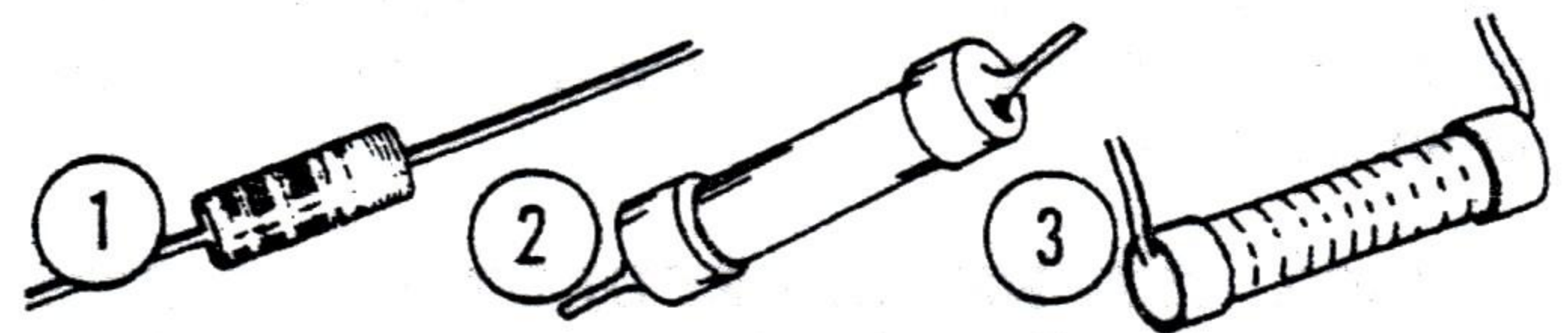

<u>Capacitors</u>		
① 20-71	1	.0013 μfd mica (1300 μμf)
② 20-75	1	.005 μfd mica (5000 μμf)
③ 21-47	1	.01 μfd disc ceramic
21-31	1	.02 μfd disc ceramic
④ 23-28	3	.1 μfd tubular

PART No.	PARTS Per Kit	DESCRIPTION
----------	---------------	-------------

Capacitors (cont'd.)

⑤ 27-19	2	1 $\mu$ fd mylar
⑥ 25-39	3	2 $\mu$ fd 150 volt electrolytic
25-95	1	10 $\mu$ fd electrolytic, 25 volts
⑦ 25-23	1	20-40-80 $\mu$ fd electrolytic, 150 volts
⑧ 31-13	1	3-12 $\mu$ fd trimmer

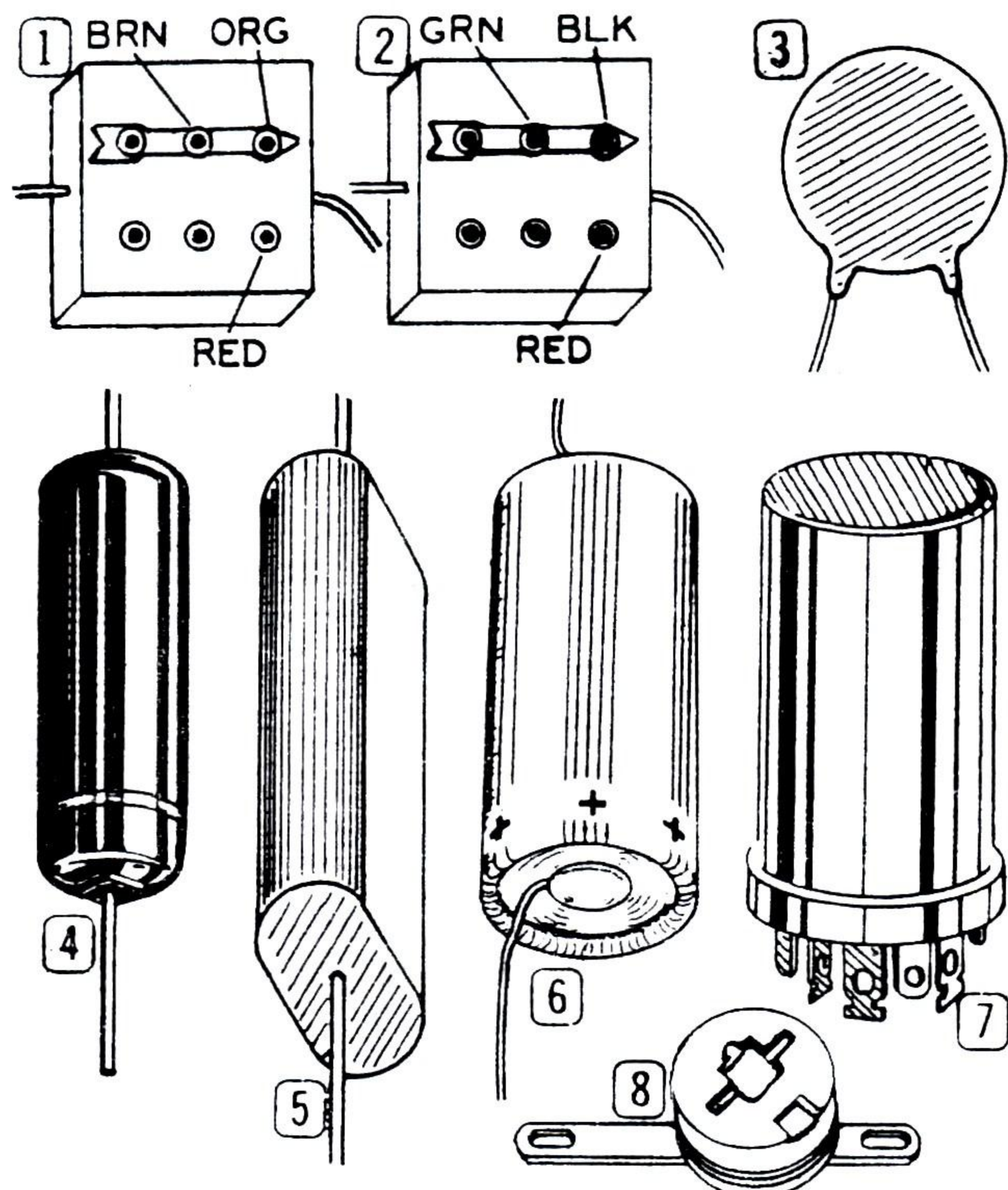

Control-Switch-Transformer

⑨ 11-16	1	40 $\Omega$ control
63-283	1	Range switch, 11-position
54-2	1	Power transformer

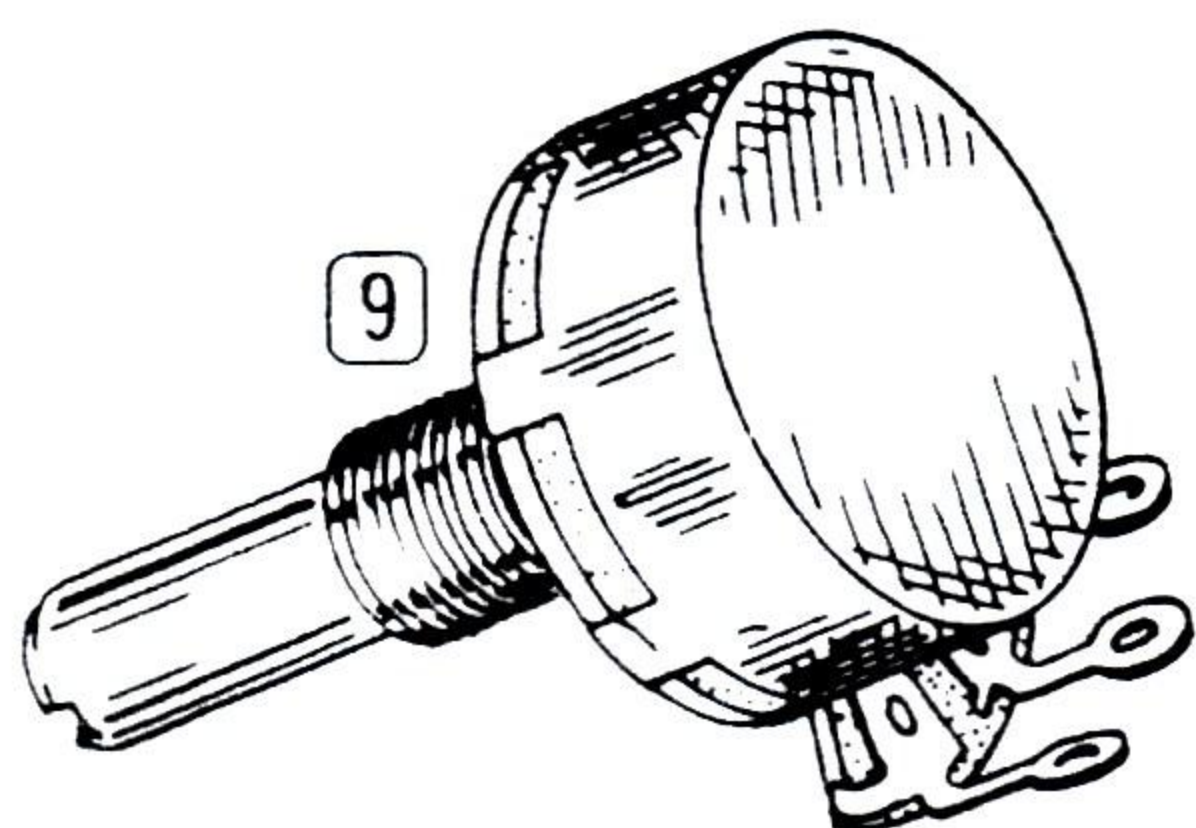

Binding Posts-Terminals

⑩ 70-5	1	Banana plug sleeve, black
70-6	1	Banana plug sleeve, red
⑪ 75-17	4	Binding post insulator

PART No.	PARTS Per Kit	DESCRIPTION
----------	---------------	-------------

Binding Posts-Terminals (cont'd.)

⑫ 100-16-2	1	Binding post cap, black
------------	---	-------------------------

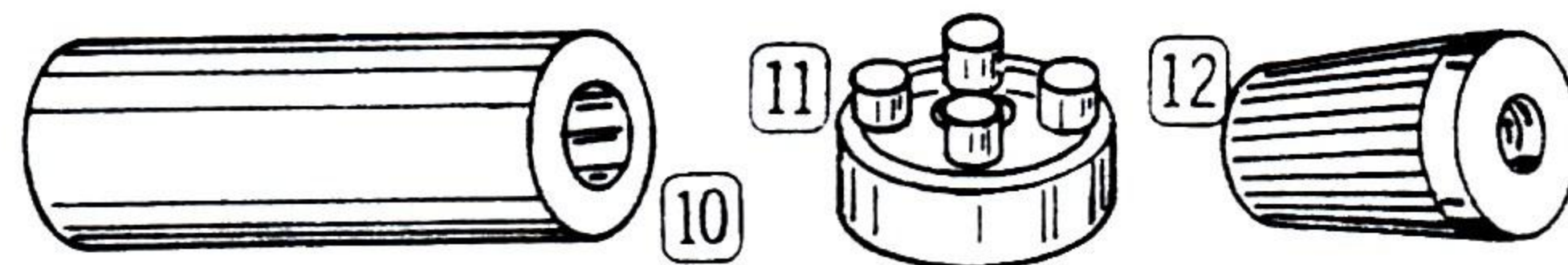

100-16-18	1	Binding post cap, red
⑬ 427-3	2	Binding post base
⑭ 431-5	1	4-lug terminal strip

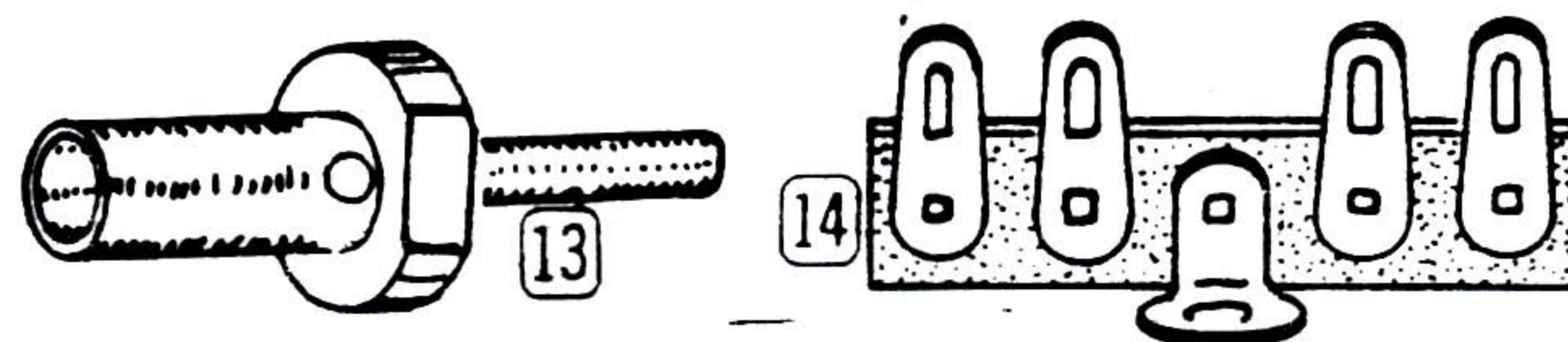

⑮ 431-12	1	4-lug terminal strip
⑯ 431-14	1	2-lug terminal strip
⑰ 431-16	3	2-lug terminal strip

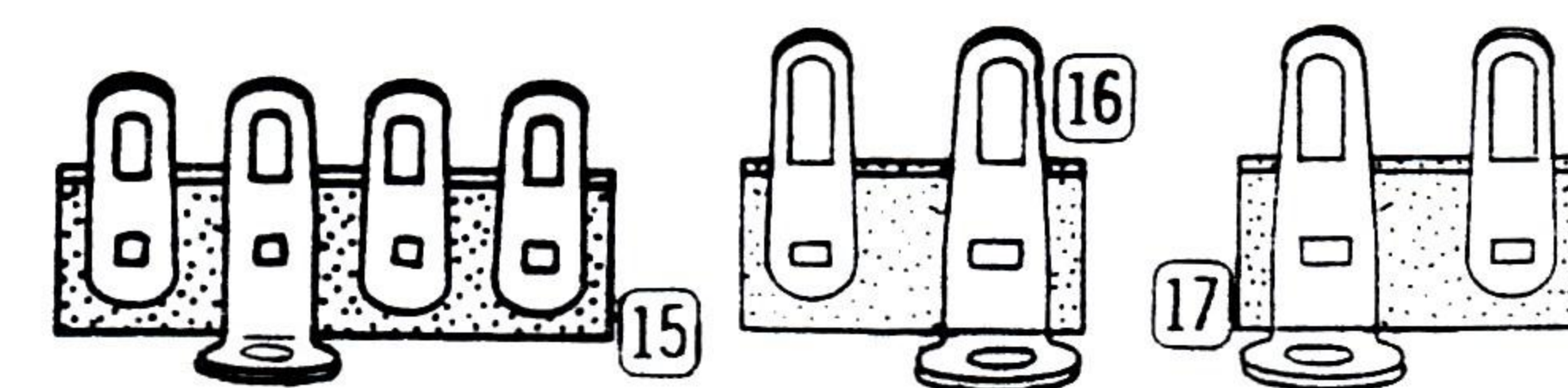

⑱ 431-40	1	4-lug terminal strip
⑲ 431-50	1	1-lug terminal strip
⑳ 438-13	2	Banana plug

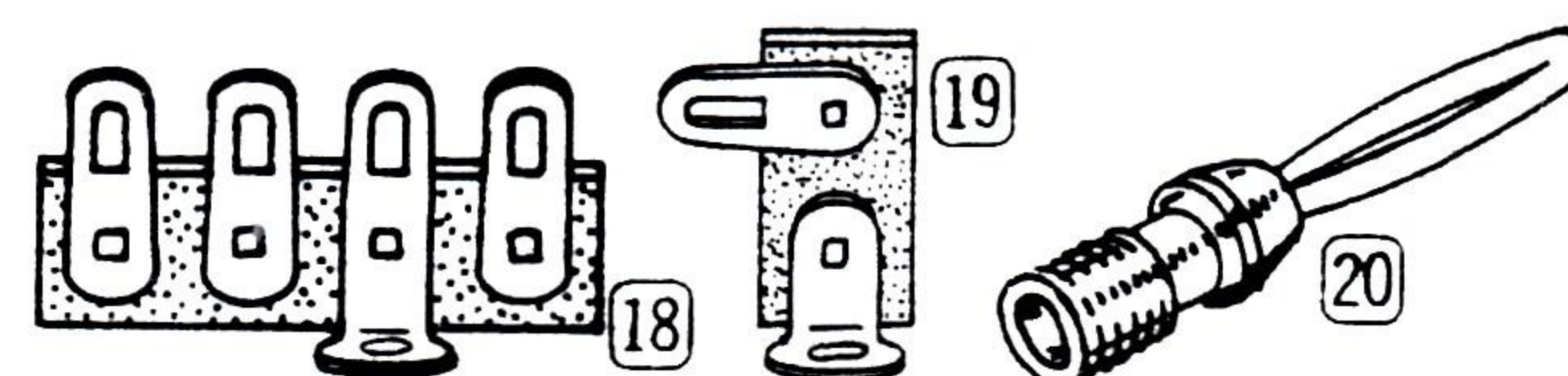

Hardware

⑳ 250-56	12	6-32 x 1/4" screw
㉑ 250-48	2	6-32 x 1/2" screw
㉒ 250-49	4	3-48 x 1/4" screw
㉓ 250-83	2	#10 x 1/2" handle screw



250-89	1	6-32 x 3/8" screw
㉔ 252-1	4	3-48 nut
㉕ 252-3	16	6-32 nut
㉖ 252-7	2	Control nut
㉗ 440-11	1	Plastic control guard
㉘ 252-22	2	6-32 speednut

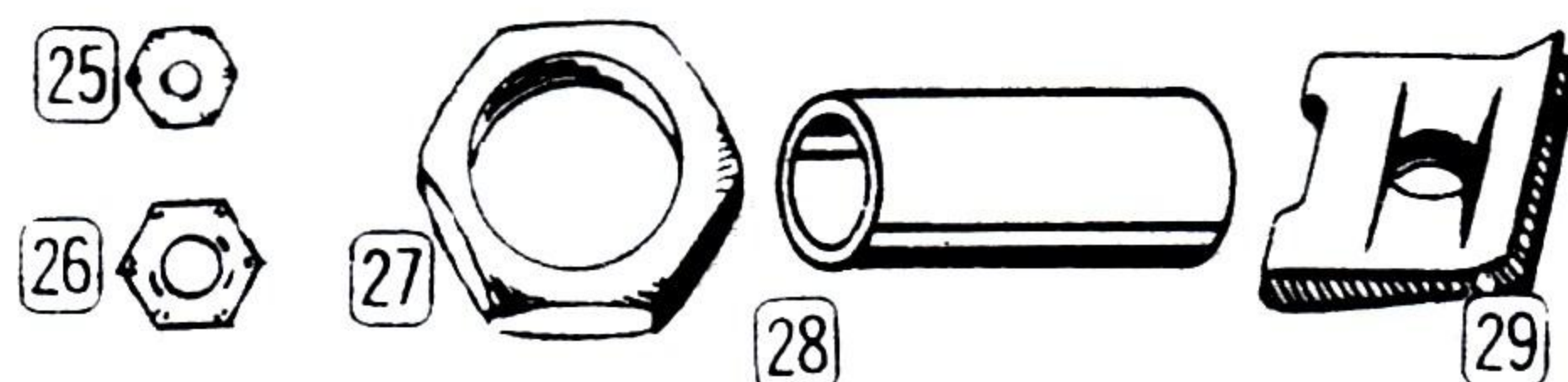

PART No.	PARTS Per Kit	DESCRIPTION
----------	---------------	-------------

Hardware (cont'd.)

① 253-10	2	Flat control washer
② 254-1	21	#6 lockwasher
③ 254-4	2	Control lockwasher
④ 254-7	4	#3 lockwasher

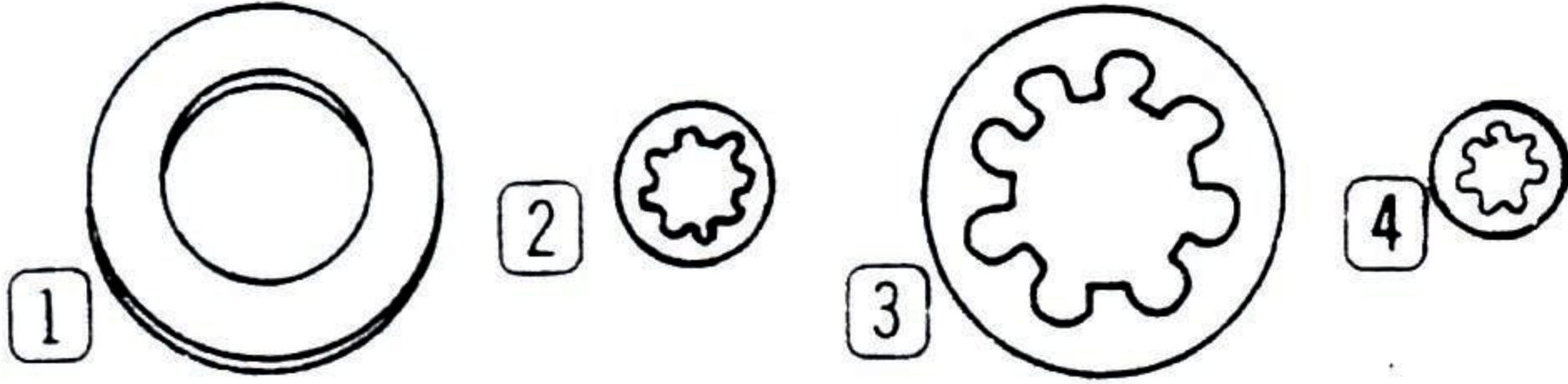

⑤ 255-17	1	6-32 tapped spacer
⑥ 259-1	3	#6 solder lug
⑦ 260-1	2	Alligator clip

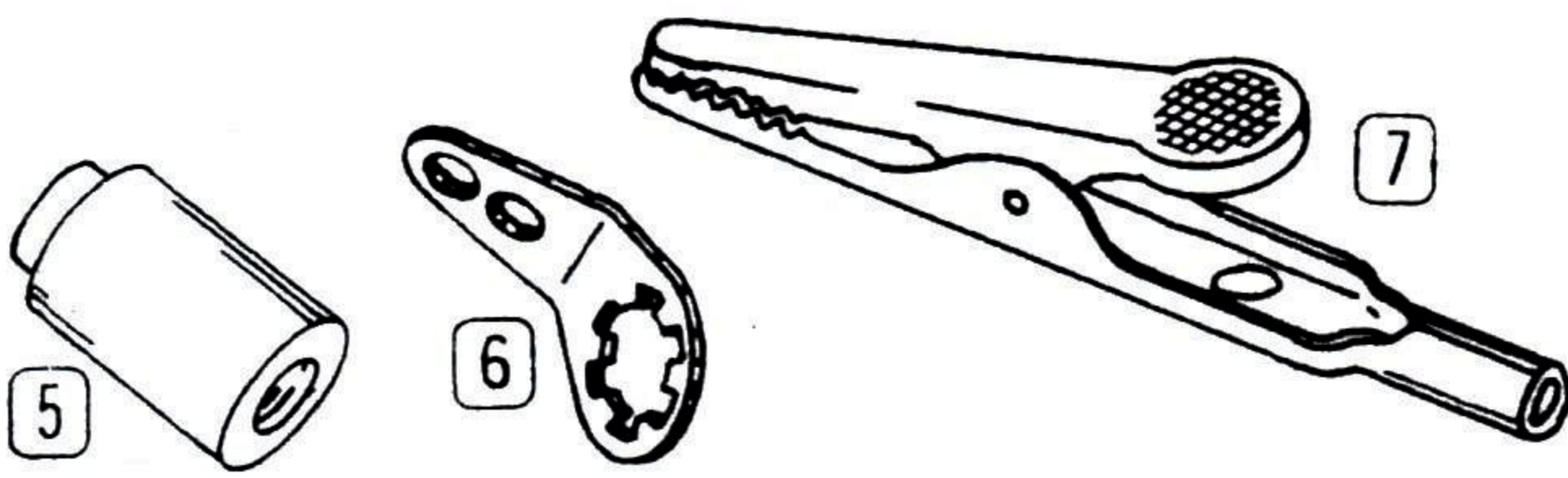

Wire-Sleeving

89-1	1	Line cord
340-8	1	Length bare wire
341-1	1	Length black test lead
341-2	1	Length red test lead
344-59	1	Length hookup wire
346-1	1	Length sleeving
346-6	1	Length 3/8" sleeving
347-9	1	Length 3-conductor shielded cable

Tubes-Lamp-Sockets

411-96	1	6AW8 tube
411-160	1	6EJ7/EF184 tube
412-1	1	#47 lamp
⑧ 434-43	2	9-pin tube socket
⑨ 434-44	1	Pilot lamp socket

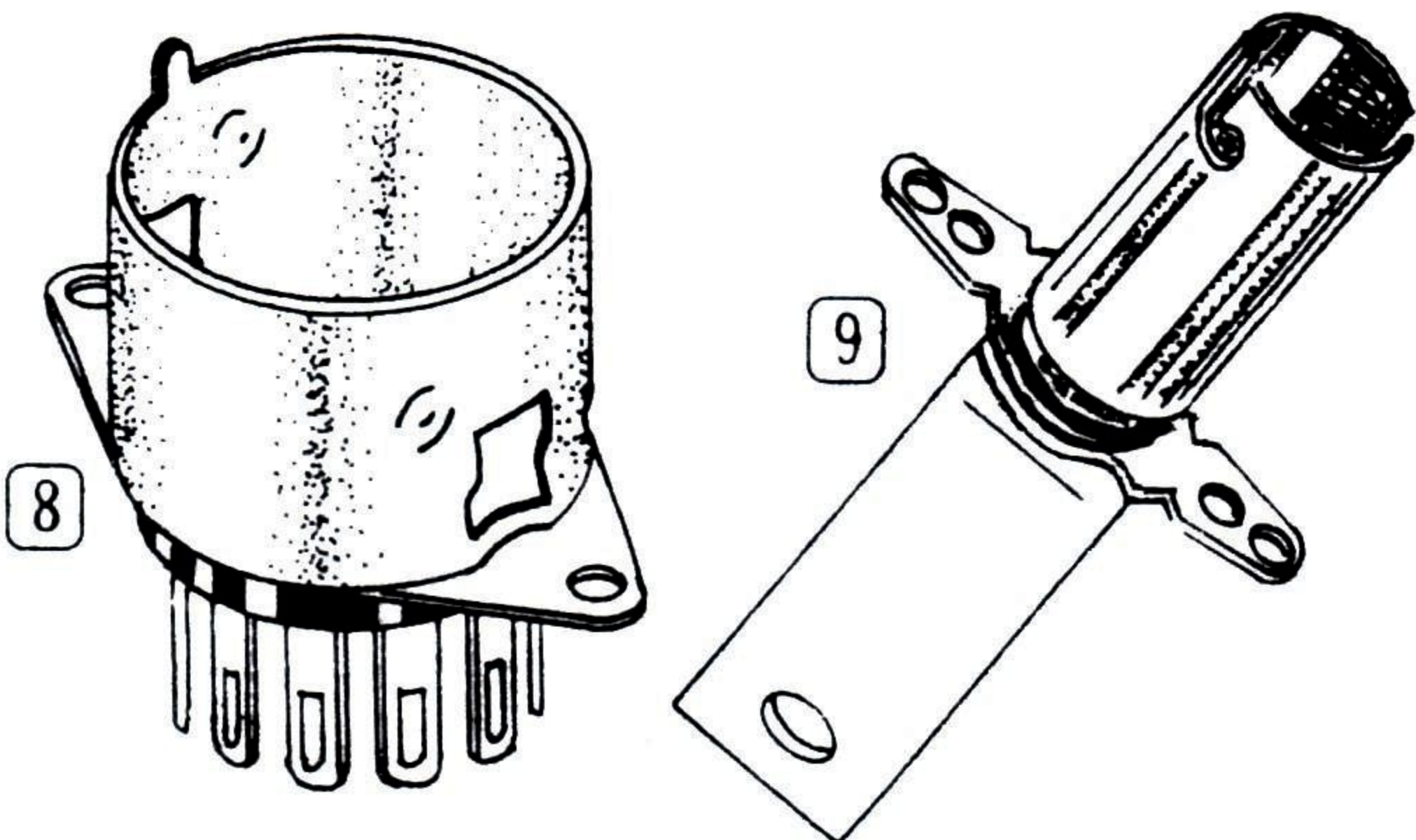

PART No.	PARTS Per Kit	DESCRIPTION
----------	---------------	-------------

Sheet Metal Parts

⑩ 200-309	1	Top chassis
⑪ 200-310	1	Bottom chassis

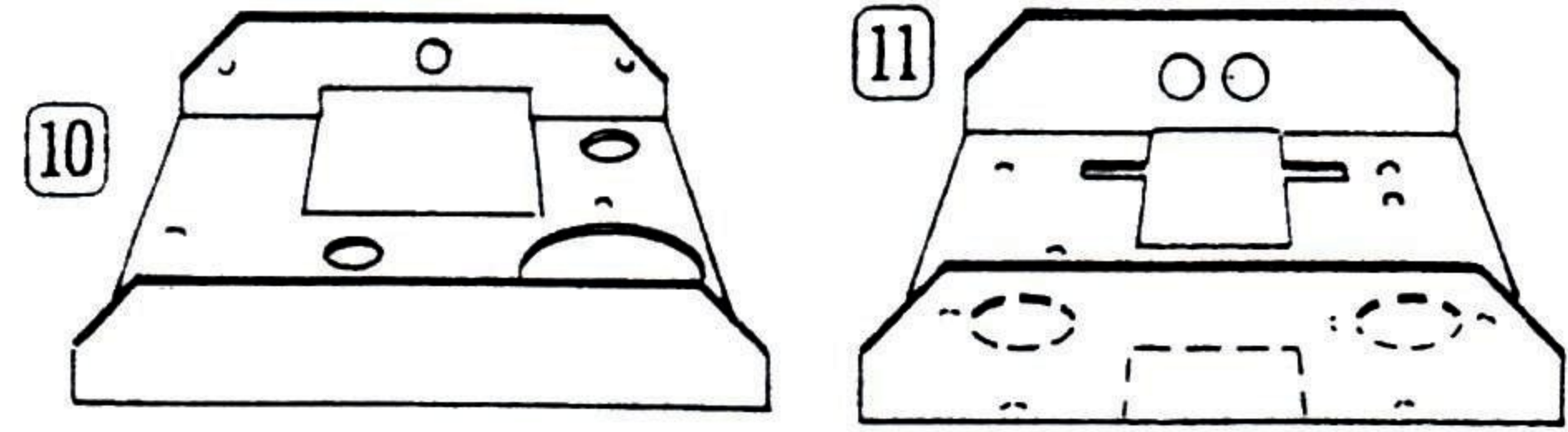

203-105-2	1	Front panel
⑫ 205-316	1	Back plate
⑬ 206-179	1	Switch shield
90-180	1	Cabinet

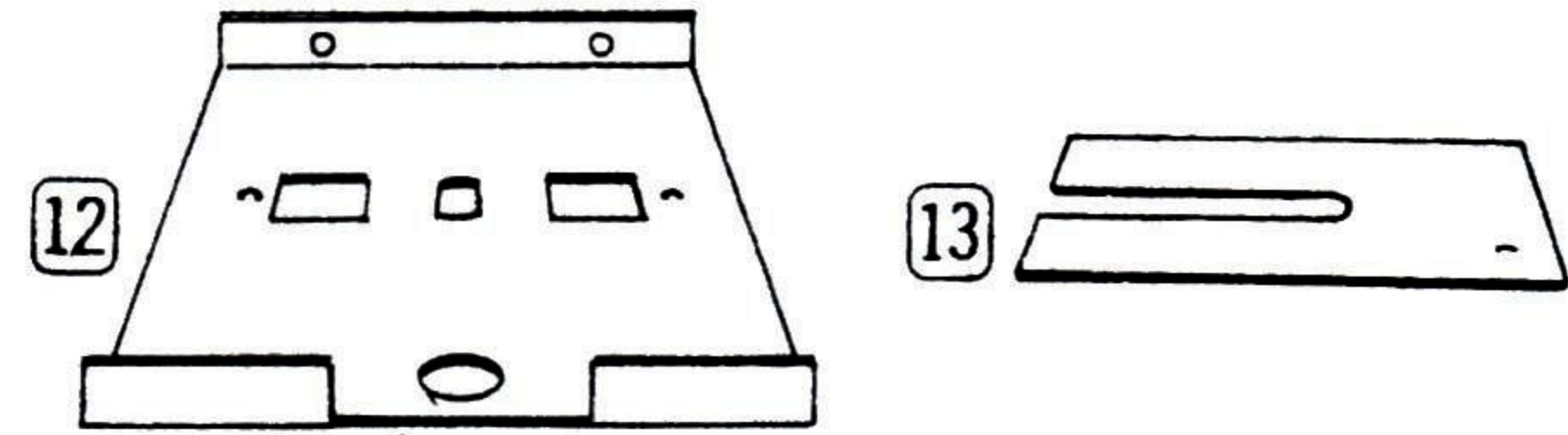

Miscellaneous

⑭ 56-26	4	Crystal diode
⑮ 57-27	1	Silicon rectifier
⑯ 73-1	2	Rubber grommet
⑰ 206-54	2	9-pin tube shield

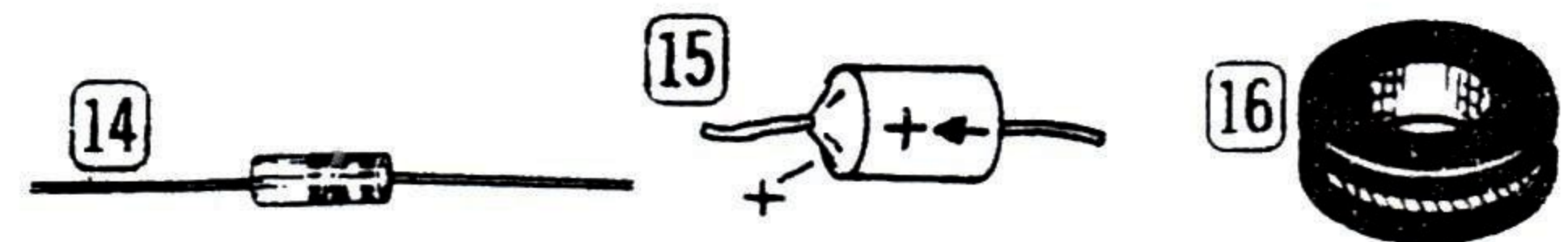

211-15	1	Handle
⑱ 75-24	1	Strain relief insulator
⑲ 261-4	4	Rubber feet
407-85	1	Meter
462-187	1	Knob
⑳ 481-1	1	Capacitor mounting wafer
331-6		Solder
595-455	1	Manual

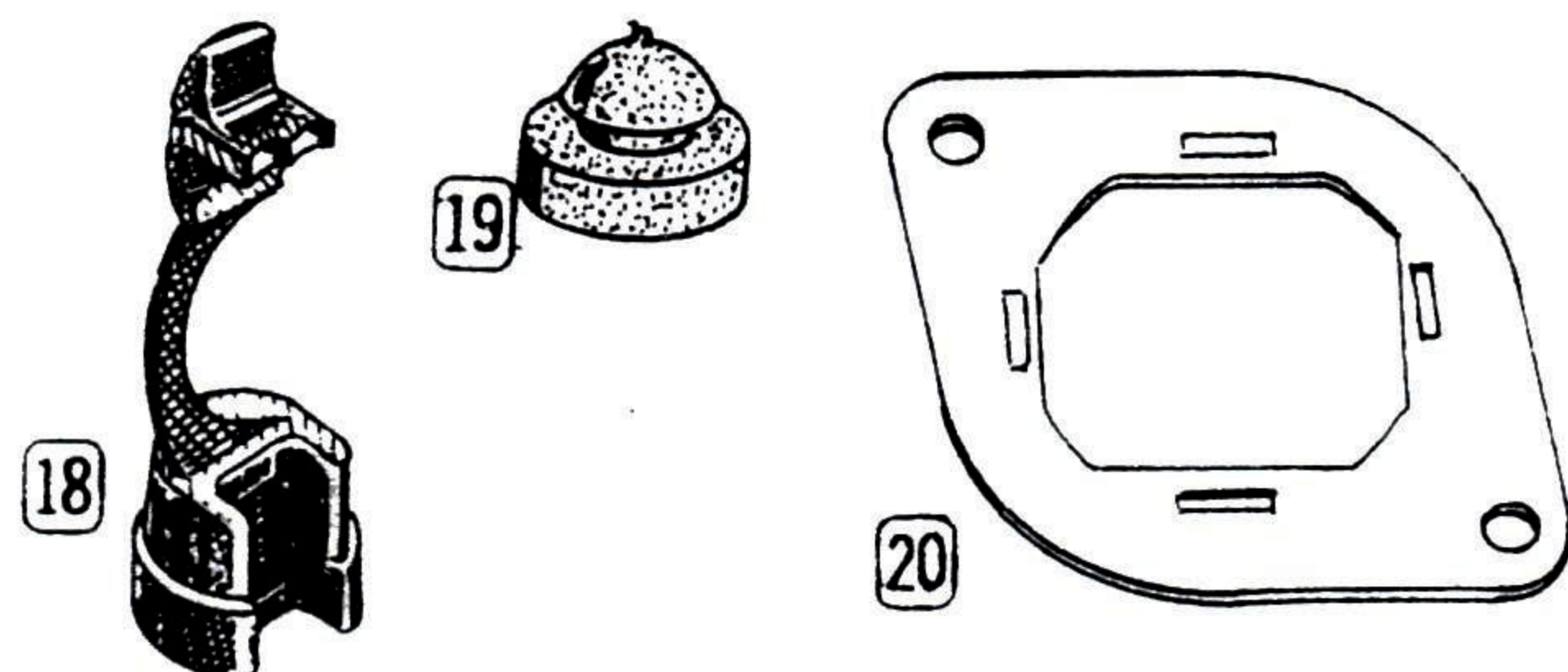

## PROPER SOLDERING TECHNIQUES

Only a small percentage of HEATHKIT equipment purchasers find it necessary to return an instrument for factory service. Of these instruments, by far the largest portion of malfunctions are due to poor or improper soldering.

If terminals are bright and clean and free of wax, frayed insulation and other foreign substances, no difficulty will be experienced in soldering. Correctly soldered connections are essential if the performance engineered into a kit is to be fully realized. If you are a beginner with no experience in soldering, a half hour's practice with some odd lengths of wire may be a worthwhile investment.

For most wiring, a 25 to 100 watt iron or its equivalent in a soldering gun is very satisfactory. A lower wattage iron than this may not heat the connection enough to flow the solder smoothly over the joint. Keep the iron tip clean and bright by wiping it from time to time with a cloth.

### CHASSIS WIRING AND SOLDERING

1. Unless otherwise indicated, all wire used is the type with colored insulation (hookup wire); the size of the conductor is the same for all colors of hookup wires furnished with this kit. In preparing a length of hookup wire, 1/4" of insulation should be removed from each end unless directed otherwise in the construction step.
  2. To avoid breaking internal connections when stripping insulation from the leads of transformers or similar components, care should be taken not to pull directly on the lead. Instead, hold the lead with pliers while it is being stripped.
  3. Leads on resistors, capacitors and similar components are generally much longer than they need to be to make the required connections. In these cases, the leads should be cut to proper length before the part is added to the chassis. In general, the leads should be just long enough to reach their terminating points.
  4. Wherever there is a possibility of bare leads shorting to other parts or to the chassis, the leads should be covered with insulating sleeving. Where the use of sleeving is specifically intended, the phrase "use sleeving" is included in the associated construction step. In any case where there is the possibility of an unintentional short circuit, sleeving should be used. Extra sleeving is provided for this purpose.
  5. Crimp or bend the lead (or leads) around the terminal to form a good joint without relying on solder for physical strength. If the wire is too large to allow bending or if the step states that the wire is not to be crimped, position the wire so that a good solder connection can still be made.
  6. Position the work, if possible, so that gravity will help to keep the solder where you want it.
  7. Place a flat side of the soldering iron tip against the joint to be soldered until it is heated sufficiently to melt the solder.
  8. Then place the solder against the heated terminal and it will immediately flow over the joint; use only enough solder to thoroughly wet the junction. It is usually not necessary to fill the entire hole in the terminal with solder.
  9. Remove the solder and then the iron from the completed junction. Use care not to move the leads until the solder is solidified.
- A poor or cold solder joint will usually look crystalline and have a grainy texture, or the solder will stand up in a blob and will not have adhered to the joint. Such joints should be reheated until the solder flows smoothly over the entire junction. In some cases, it may be necessary to add a little more solder to achieve a smooth bright appearance.

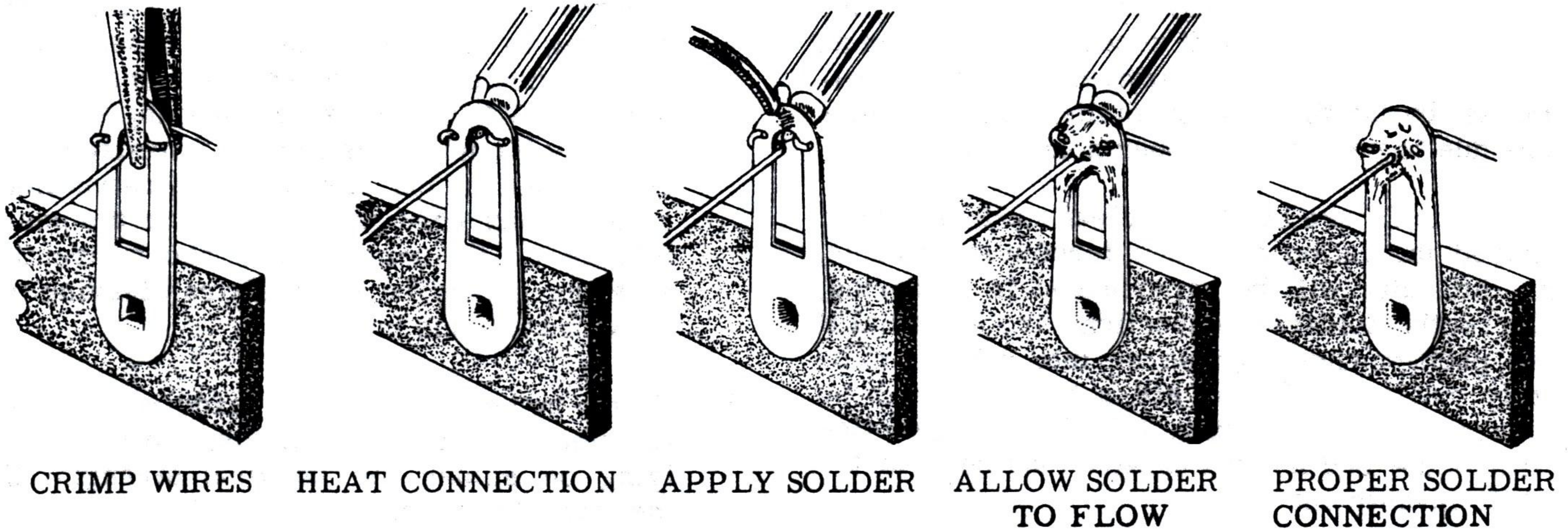

ROSIN CORE SOLDER HAS BEEN SUPPLIED WITH THIS KIT. THIS TYPE OF SOLDER MUST BE USED FOR ALL SOLDERING IN THIS KIT. ALL GUARANTEES ARE VOIDED AND WE WILL NOT REPAIR OR SERVICE EQUIPMENT IN WHICH ACID CORE SOLDER OR PASTE FLUXES HAVE BEEN USED. IF ADDITIONAL SOLDER IS NEEDED, BE SURE TO PURCHASE ROSIN CORE (60:40 or 50:50 TIN-LEAD CONTENT) RADIO TYPE SOLDER.

## STEP-BY-STEP PROCEDURE

The following instructions are presented in a logical step-by-step sequence to enable you to complete your kit with the least possible confusion. Be sure to read each step all the way through before beginning the specified operation. Also read several steps ahead of the actual step being performed. This will familiarize you with the relationship of the subsequent operations. When the step is completed, check it off in the space provided. This is particularly important as it may prevent errors or omissions, especially if your work is interrupted. Some kit builders have also found it helpful to mark each lead in colored pencil on the Pictorial as it is added.

The fold-out diagrams in this manual may be removed and attached to the wall above your working area; but, because they are an integral part of the instructions, they should be returned to the manual after the kit is completed.

In general, the illustrations in this manual correspond to the actual configuration of the kit; however, in some instances the illustra-

tions may be slightly distorted to facilitate clearly showing all of the parts.

The abbreviation "NS" indicates that a connection should not be soldered yet as other wires will be added. When the last wire is installed, the terminal should be soldered and the abbreviation "S" is used to indicate this. Note that a number will appear after each solder instruction. This number indicates the number of leads that are supposed to be connected to the terminal in point before it is soldered. For example, if the instruction reads, "Connect a lead to lug 1 (S-2)," it will be understood that there will be two leads connected to the terminal at the time it is soldered. (In cases where a lead passes through a terminal or lug and then connects to another point, it will count as two leads, one entering and one leaving the terminal.)

The steps directing the installation of resistors include color codes to help identify the parts. Also, if a part is identified by a letter-number designation on the Schematic, its designation will appear at the beginning of the construction step which directs its installation.

## STEP-BY-STEP ASSEMBLY

Refer to Pictorial 1 (fold-out from Page 11) for the following steps.

NOTE: Be careful not to mar the front of the meter when assembling the kit. The front of the meter can be covered with paper or some other protective material during assembly.

- ( ) Mount the meter on the front panel as shown, using the brass lockwashers and nuts packed in the cellophane bag with the meter. Using an extra #6 lockwasher, mount a 4-lug terminal strip under the lower left-hand nut as shown in Detail 1A. Do not tighten the two top nuts all the way at this time as they will be removed later.

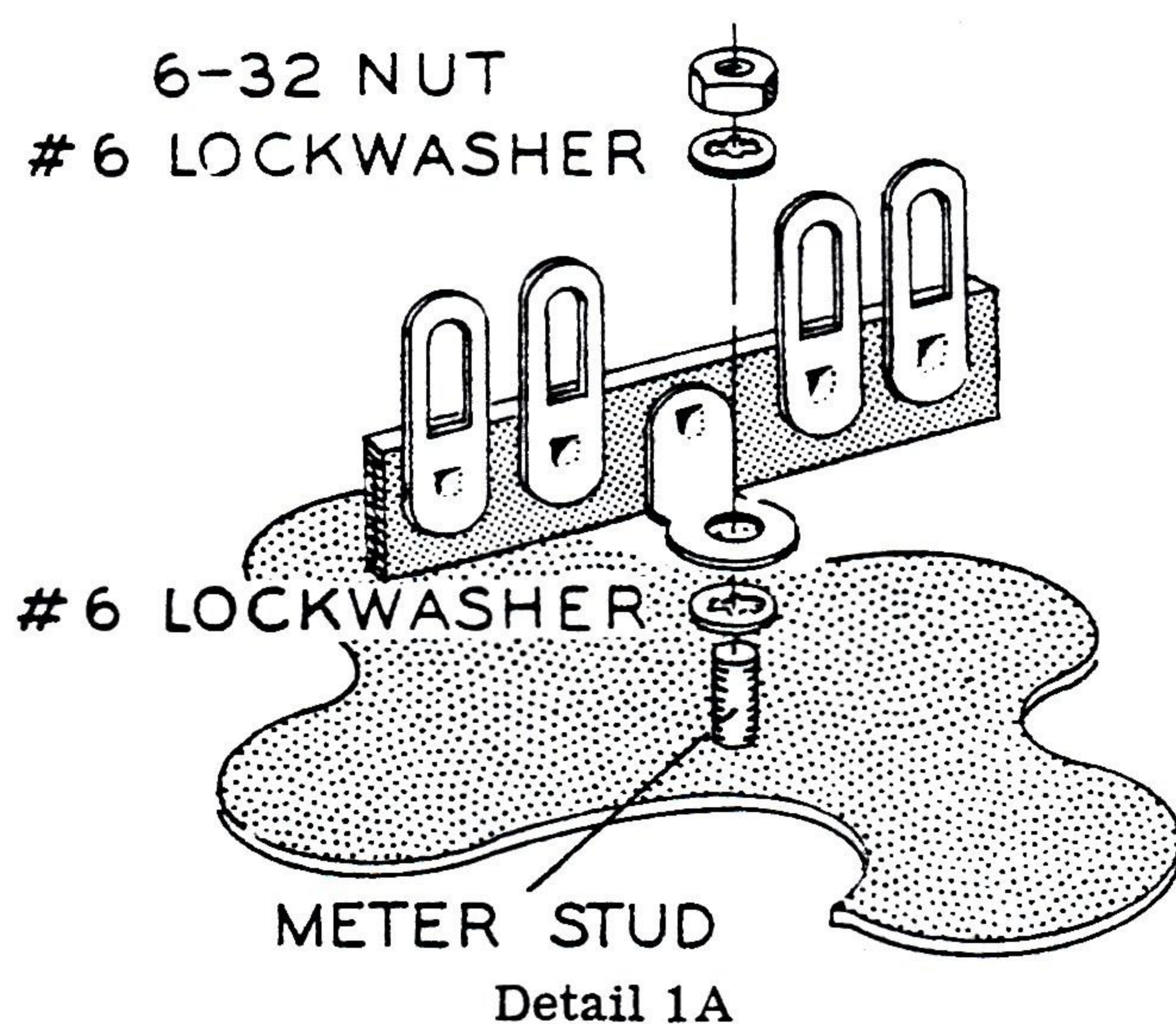

CAUTION: A crystal diode can be damaged by excessive heat while soldering. To avoid damage, place an alligator clip over the lead or leads to be soldered between the body of the diode and the point to be soldered. See Detail 1B. The alligator clips will now absorb the heat; do not release them until the connection is cool.

- ( ) Clip both leads of one of the crystal diodes to a length of 1/2". Connect the lead from the banded end of this crystal diode to lug 1 (NS) and connect the other lead to lug 2 (NS) of terminal strip A.
- ( ) Clip each lead of a crystal diode to a length of 1/2". Connect the lead from the banded end of this crystal diode to lug 3 (NS) and connect the other lead to lug 4 (NS) of terminal strip A.

- ( ) Connect one end of an 8" length of hookup wire to lug 1 of terminal strip A (NS). Leave the other end of this wire free.
- ( ) Connect the lead from the banded end of a crystal diode to lug 1 of the meter (NS). Connect the other lead of this crystal diode to lug 1 of terminal strip A (S-3).
- ( ) Connect a 3-1/2" length of hookup wire from lug 2 of terminal strip A (NS) to lug 2 of the meter (NS).
- ( ) Connect a 2-1/4" length of hookup wire from lug 3 of terminal strip A (S-2) to lug 1 of the meter (NS).
- ( ) C16. Connect a .1  $\mu$ fd tubular capacitor between lug 1 (S-3) and lug 2 (S-2) of the meter. Be sure that the lead from the banded end of the capacitor is connected to lug 2 as shown.
- ( ) Place 1/2" of sleeving over each lead of a crystal diode. Connect the lead from the banded end of this crystal diode to lug 4 (NS) and connect the other lead to lug 2 (S-3) of terminal strip A.

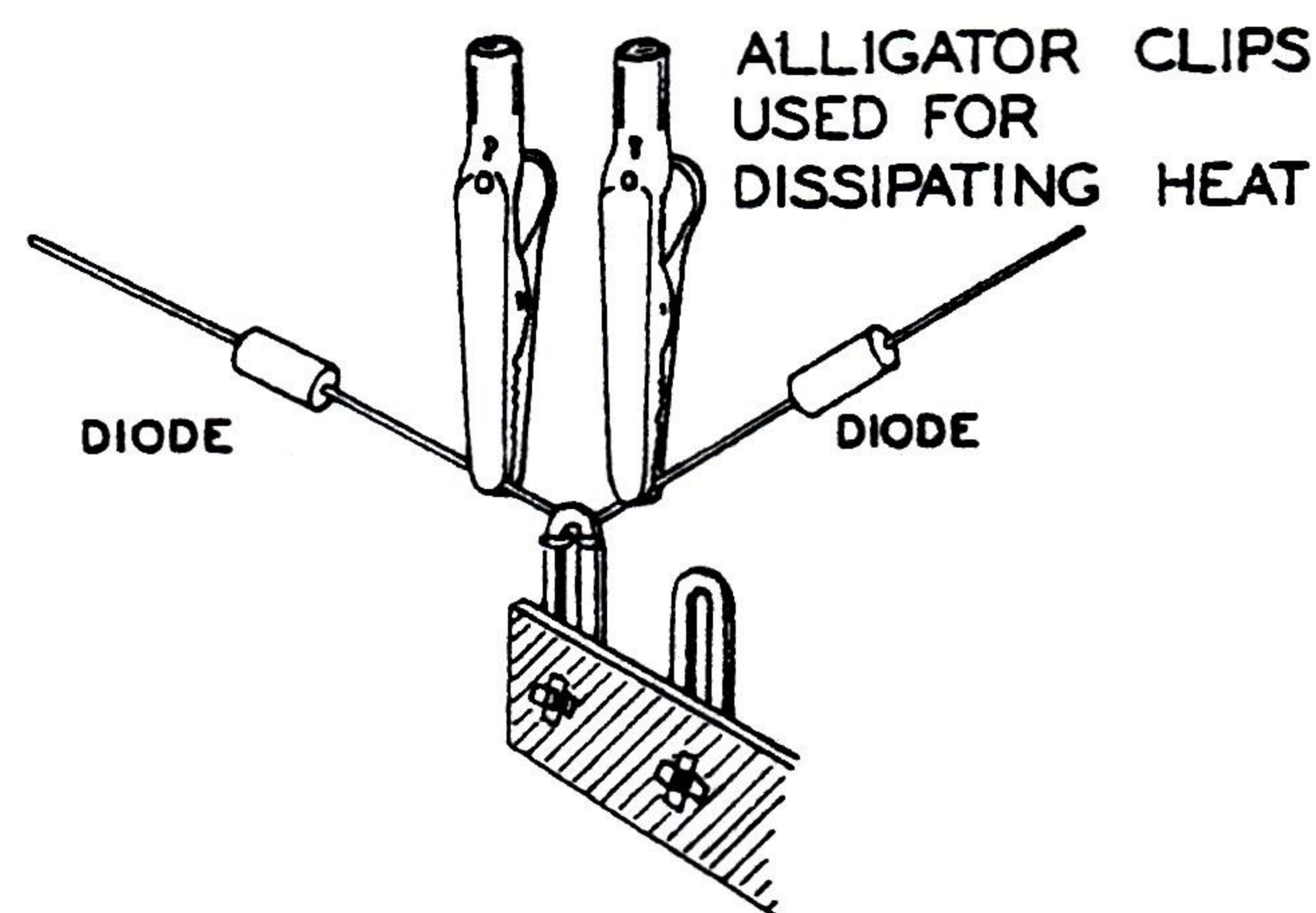

## RANGE SWITCH WIRING

- ( ) Mount the range switch on the front panel as shown in Detail 1C, using a control lockwasher, a flat control washer, a control nut, and a control nut. Orient the switch as shown in Pictorial 1.

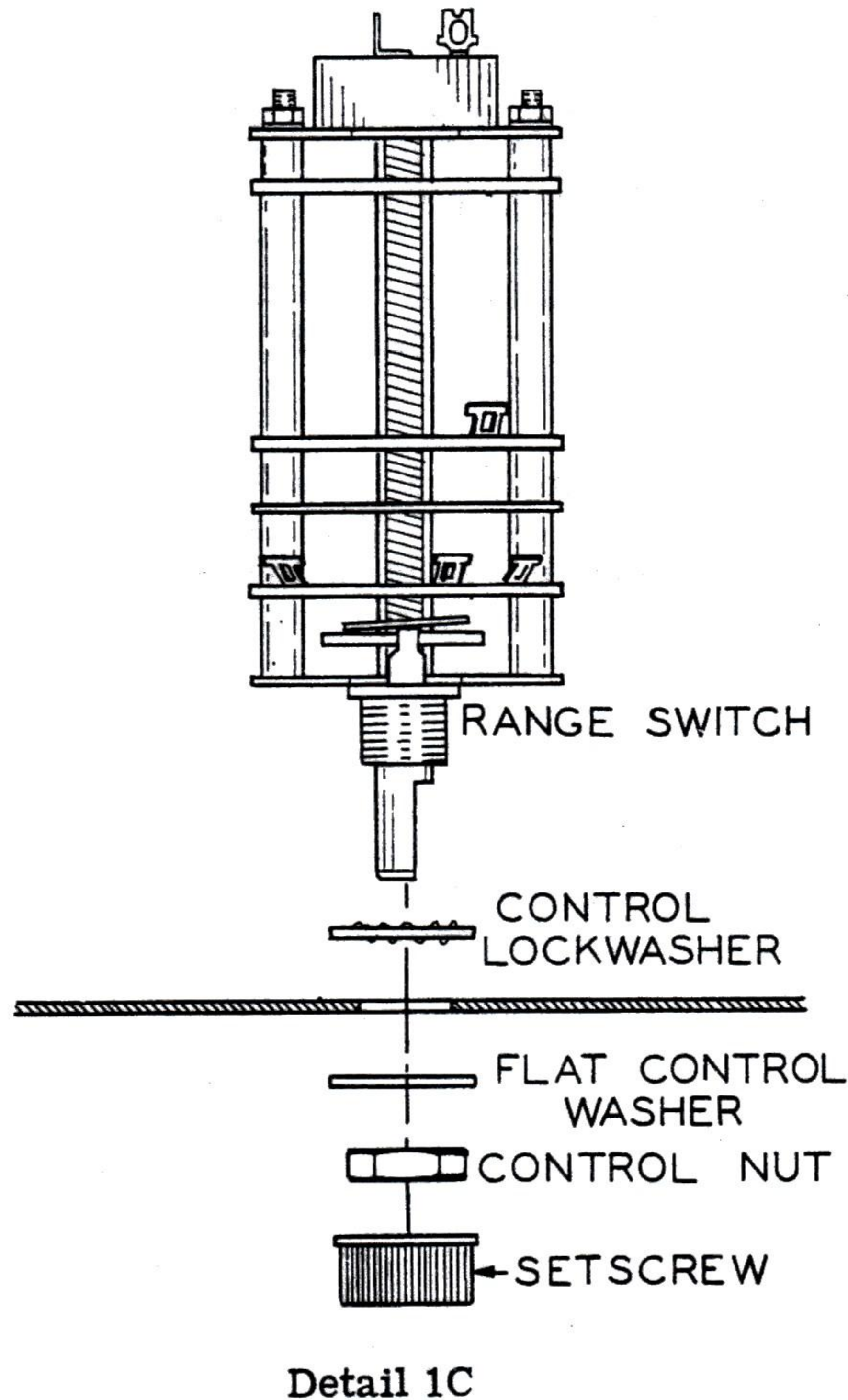

- ( ) Install the knob on the range switch shaft and tighten the setscrew of the knob against the flat of the shaft. With the shaft rotated fully counterclockwise, the pointer should line up with the .01 marking on the front panel. To achieve this positioning, it may be necessary to loosen the control nut and rotate the switch slightly.
- ( ) C2, R1. Connect the 10 megohm precision resistor to the trimmer capacitor as shown in Detail 1D. Solder the leads at each end of the trimmer capacitor, but do NOT cut off the leads.

- ( ) Connect this trimmer-resistor combination from lug 7 (NS) to lug 8 (NS) on deck A of the range switch.
- ( ) C1. Cut both leads of a .02  $\mu$ fd disc ceramic capacitor to a length of 1/2". Connect one of these leads to lug 7 on deck A of the range switch (S-2). Leave the other lead free.
- ( ) Connect a 1" length of bare wire from lug 8 (S-2) to lug 1 (NS) on deck A of the range switch. Place this wire away from the metal parts of the switch.
- ( ) C8. Cut the lead at the unbanded end of a .1  $\mu$ fd tubular capacitor to a length of 3/4". Connect this lead to lug 7 on deck B of the range switch (S-1). Leave the other lead free.

Refer to Pictorial 2 for the following steps.

- ( ) R13. Connect a 100  $\Omega$  precision resistor from lug 1 on deck B (NS) to lug 1 on deck C (NS) of the range switch.
- ( ) Connect a 1-1/2" length of bare wire from lug 2 on deck C (NS) to lug 1 on deck B (S-2) of the range switch.
- ( ) R12. Connect a 216.2  $\Omega$  precision resistor from lug 2 on deck C (S-2) to lug 2 on deck B (NS) of the range switch.
- ( ) Connect a 1-1/2" length of bare wire from lug 2 on deck B (S-2) to lug 3 on deck C (NS) of the range switch.
- ( ) R11. Connect a 683.8  $\Omega$  precision resistor from lug 3 on deck C (S-2) to lug 3 on deck B (NS) of the range switch.
- ( ) Connect a 1-1/2" length of bare wire from lug 3 on deck B (S-2) to lug 4 on deck C (NS) of the range switch.

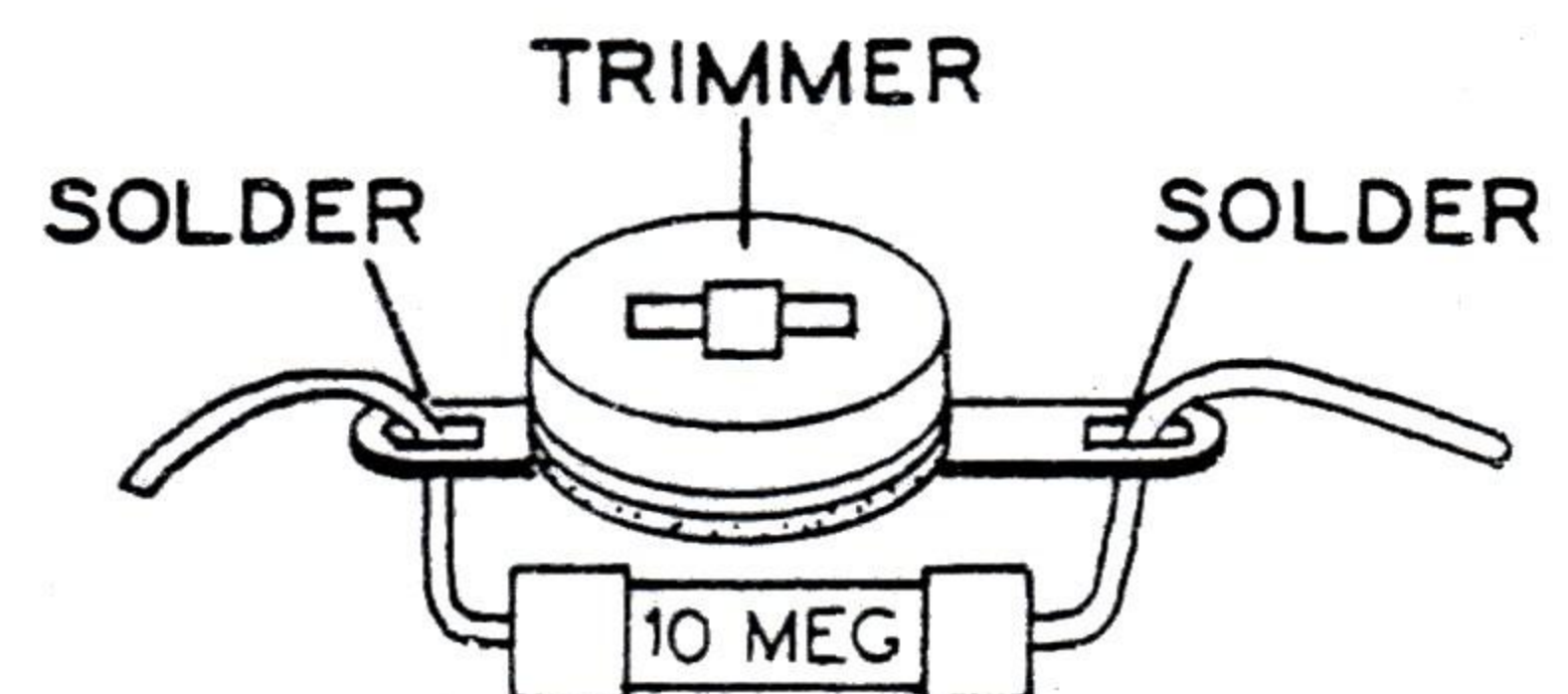

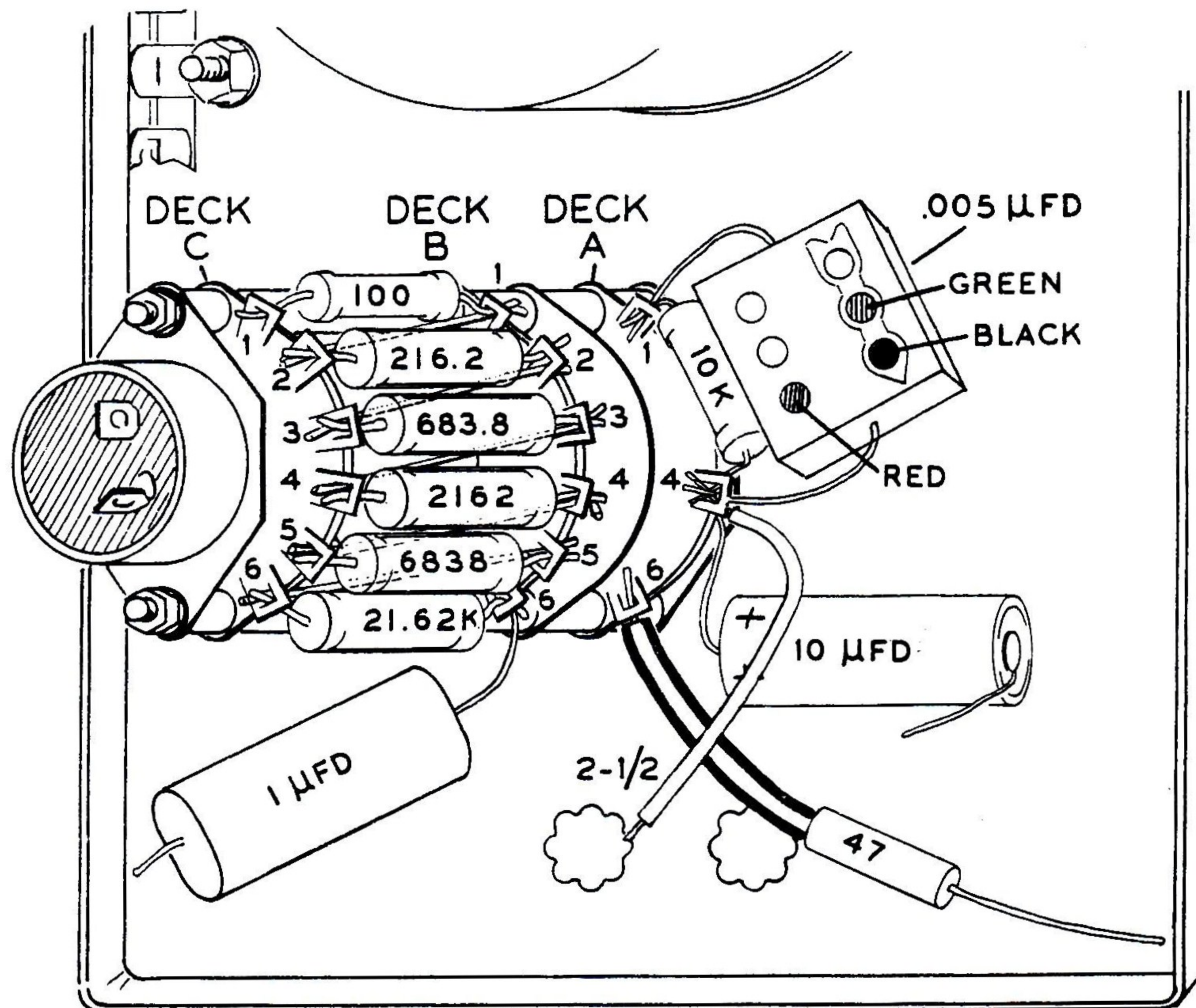

Pictorial 2

- ( ) R10. Connect a 2162  $\Omega$  precision resistor from lug 4 on deck C (S-2) to lug 4 on deck B (NS) of the range switch.
- ( ) C3. Connect a .005  $\mu$ fd mica capacitor from lug 1 (S-3) to lug 4 (NS) on deck A of the range switch.
- ( ) Connect a 1-1/2" length of bare wire from lug 4 on deck B (S-2) to lug 5 on deck C (NS) of the range switch.
- ( ) R9. Connect a 6838  $\Omega$  precision resistor from lug 5 on deck C (S-2) to lug 5 on deck B (NS) of the range switch.
- ( ) C4. Cut the positive (+) lead of the 10  $\mu$ fd electrolytic capacitor to a length of 1". Connect this lead to lug 4 on deck A of the range switch (S-4). Leave the other lead free.
- ( ) Connect a 1-1/2" length of hookup wire from lug 5 on deck B (S-2) to lug 6 on deck C (NS) of the range switch.
- ( ) R4. Place sleeving over one lead of a 47  $\Omega$  (yellow-violet-black) resistor and connect it to lug 6 on deck A of the range switch (S-1). Leave the other lead free.
- ( ) R8. Connect a 21.62 K $\Omega$  precision resistor from lug 6 on deck C (S-2) to lug 6 on deck B (NS) of the range switch.
- ( ) C6. Cut one lead of a 1  $\mu$ fd mylar capacitor to a length of 3/4". Connect this lead to lug 6 on deck B of the range switch (S-2). Leave the other lead free.
- ( ) R2. Connect a 10 K $\Omega$  precision resistor from lug 1 (NS) to lug 4 (NS) on deck A of the range switch.

## TOP CHASSIS WIRING

Refer to Pictorial 3 for the following steps.

- ( ) Place the top chassis on your work surface in front of you as shown in Pictorial 3.
- ( ) Install two grommets in the positions shown.
- ( ) Install the #47 lamp in the pilot lamp socket and place the length of 3/8" sleeving over the lamp.
- ( ) Mount the pilot lamp socket along with 2-lug terminal strip C. Use a 6-32 x 1/4" screw, two #6 lockwashers (one under the nut, and one between the lamp bracket and the terminal strip mounting foot), and a 6-32 nut.
- ( ) Insert the yellow and red leads through the grommet and mount the power transformer as shown in Detail 3A. Use a 6-32 x 1/4" screw, #6 lockwasher, and 6-32 nut at the mounting hole near the edge of the chassis. Using a 6-32 x 3/8" screw in the other mounting hole, mount a 1-lug terminal strip on top of the chassis and a 4-lug terminal strip below the chassis as shown. Use three #6 lockwashers as shown and a 6-32 nut.

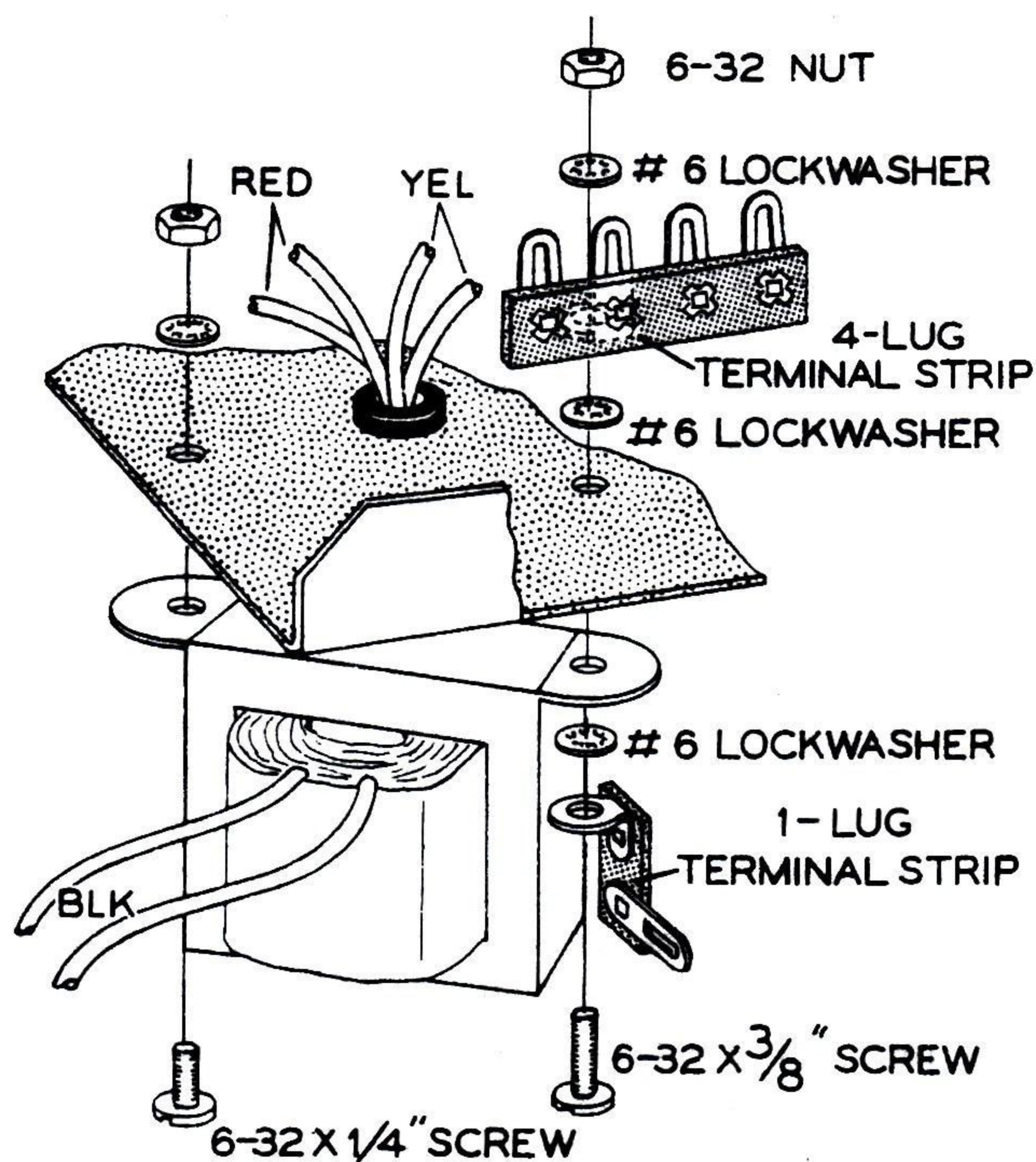

Detail 3A

- ( ) Install the capacitor mounting wafer, using a 6-32 x 1/4" screw, #6 lockwasher, and 6-32 nut in the mounting hole near the front of the chassis. The second screw will be installed in the wafer when the top chassis is connected to the back plate.
- ( ) C5, C10, C17. Mount the 20-40-80  $\mu$ fd electrolytic capacitor on the capacitor mounting wafer as shown in Detail 3B. Be sure that the blank space in the capacitor faces as shown in Pictorial 3.

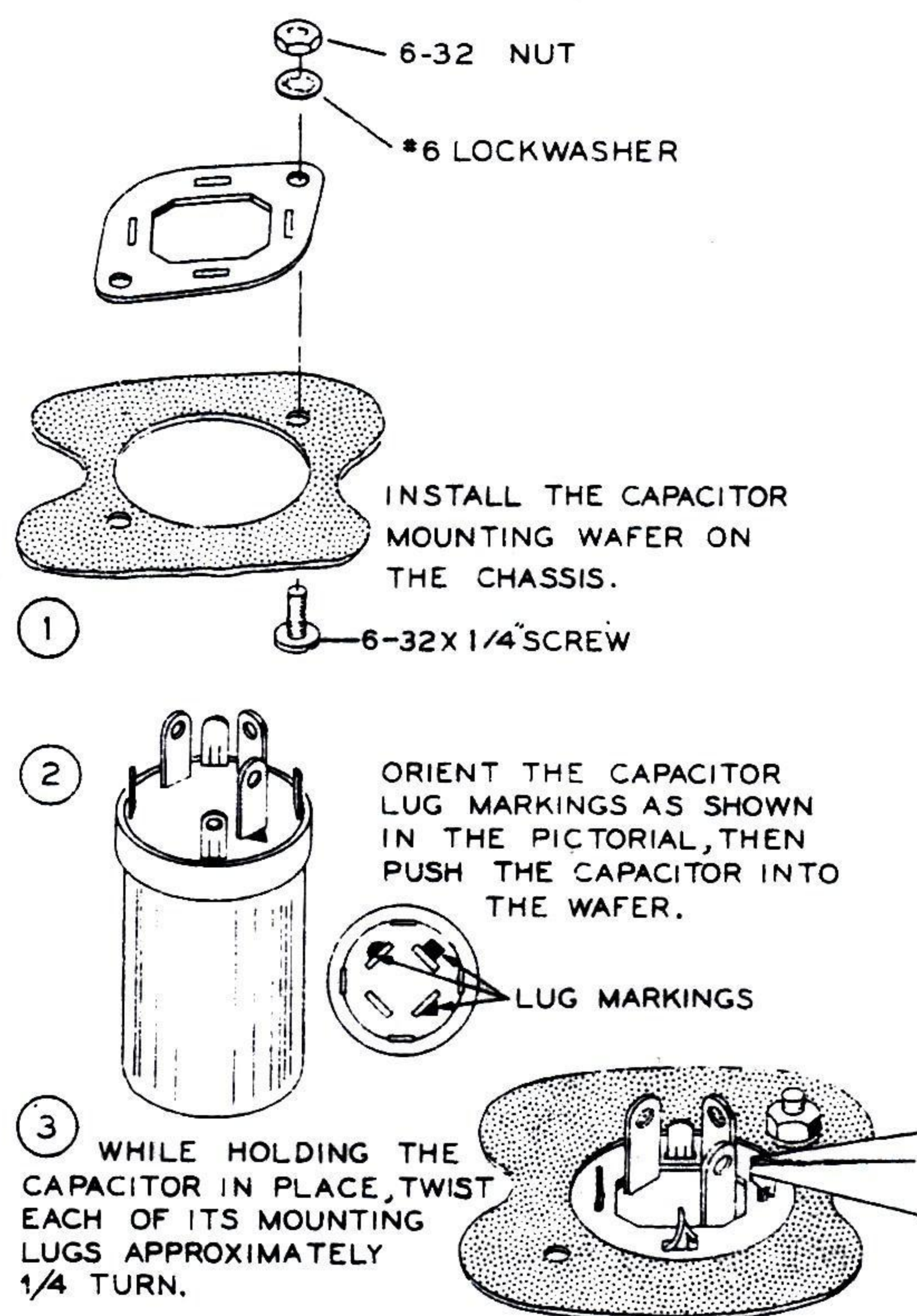

Detail 3B

- ( ) Solder one of the mounting lugs of the filter capacitor to the capacitor mounting wafer. This is done to insure the best possible ground connection.

NOTE: The purpose of using twisted pairs of hookup wire is to cancel hum in the filament leads. Best results will be obtained if the wires are twisted approximately two complete turns per inch.

- ( ) Twist together two 3-1/2" hookup wires. At one end of these twisted wires, connect one of the wires to lug 1 (NS) and connect the other wire to lug 2 (NS) of the pilot lamp socket.

NOTE POSITION OF  
BANDED END  
ON DIODES

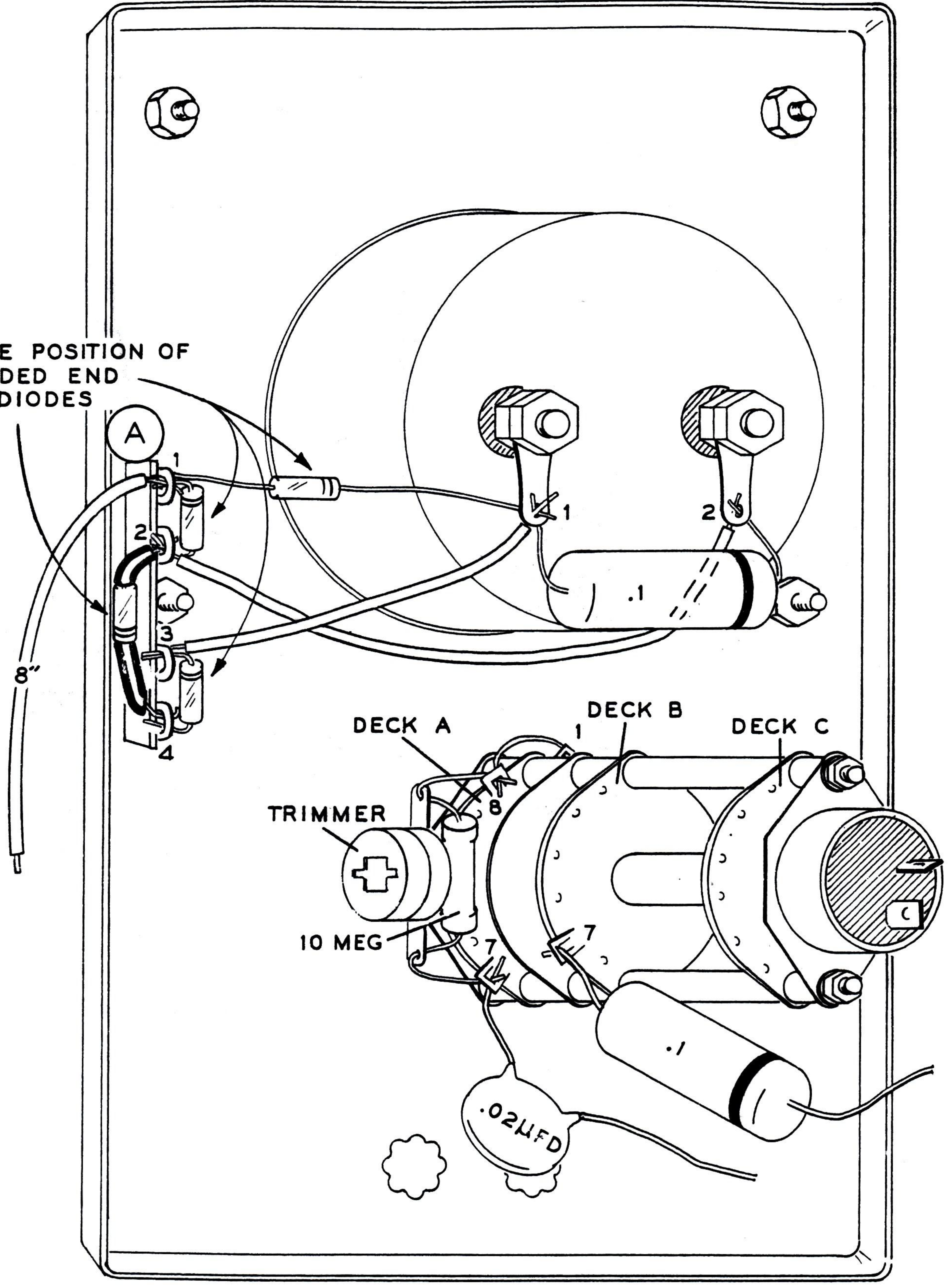

Pictorial 1

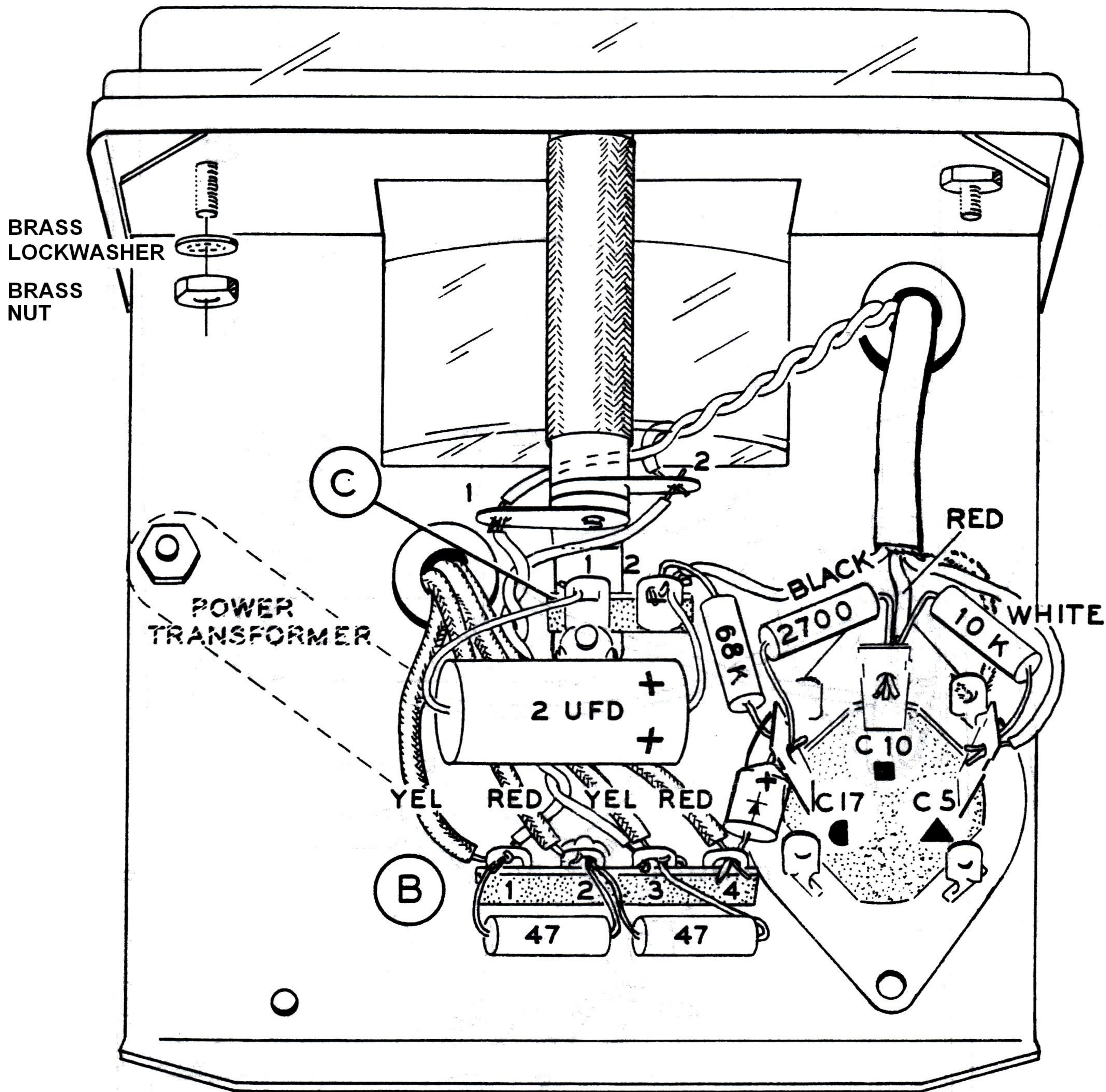

Pictorial 3

- ( ) At the other end of these twisted wires, connect one wire to lug 1 (NS) and connect the other wire to lug 3 (NS) of terminal strip B.
- ( ) Twist together two 11-1/2" hookup wires. At one end of these twisted hookup wires, connect one wire to lug 1 (S-2) and connect the other wire to lug 2 (S-2) of the pilot lamp socket. Insert the other end of this twisted pair down through the grommet as shown, it will be connected later.

NOTE: In each of the following steps, cut the indicated power transformer lead to the correct length, remove 1/4" of insulation and "tin" the end. ("Tin" means to melt a small amount of solder on the exposed lead end.)

- ( ) Connect one of the yellow leads to lug 1 of terminal strip B (NS).
- ( ) Connect one of the red leads to lug 2 of terminal strip B (NS).
- ( ) Connect the other yellow lead to lug 3 of terminal strip B (NS).
- ( ) Connect the other red lead to lug 4 of terminal strip B (NS).
- ( ) Prepare a 12-1/2" length of 3-conductor shielded cable as shown in Detail 3C.
- ( ) Insert the end of the cable that has the 1" shield up through the grommet and connect the leads as follows:
  - ( ) Connect the shield to the nearest ground lug of the filter capacitor (S-1).
  - ( ) Connect the red wire to the lug of electrolytic capacitor C10 (NS).
  - ( ) Connect the black wire to lug 2 of terminal strip C (NS).
  - ( ) Connect the white wire to the lug of electrolytic capacitor C5 (NS).
  - ( ) R22. Connect a 68 K $\Omega$  (blue-gray-orange) resistor from lug 2 of terminal strip C (NS) to the lug of capacitor C17 (NS).

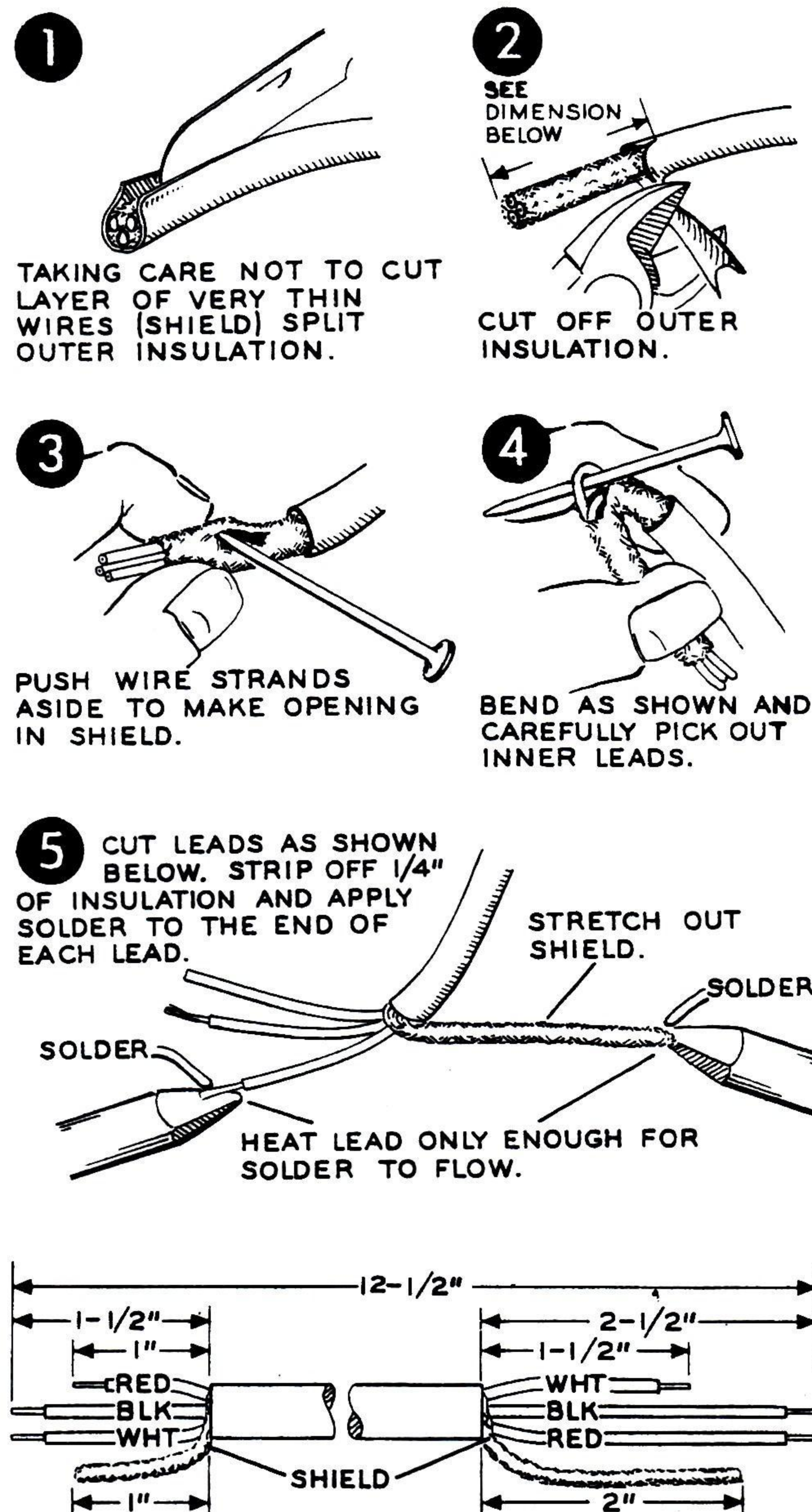

Detail 3C

- ( ) Connect the lead from the positive ( $\rightarrow$ +) end of the silicon rectifier to the lug of electrolytic capacitor C17 (NS). Connect the other lead of this silicon rectifier to lug 4 of terminal strip B (S-2).
- ( ) R21. Connect a 2700  $\Omega$  (red-violet-red) resistor from the lug of electrolytic capacitor C17 (S-3) to the lug of electrolytic capacitor C10 (NS).

- ( ) R6. Connect a 10 K $\Omega$  (brown-black-orange) resistor from the lug of electrolytic capacitor C10 (S-3) to the lug of electrolytic capacitor C5 (S-2).
- ( ) R28. Connect a 47  $\Omega$  (yellow-violet-black) resistor from lug 1 (S-3) to lug 2 (NS) of terminal strip B.
- ( ) R29. Connect a 47  $\Omega$  (yellow-violet-black) resistor from lug 2 (S-3) to lug 3 (S-3) of terminal strip B.
- ( ) C11. Connect the positive (+) lead of a 2  $\mu$ fd 150 volt electrolytic capacitor to lug 2 of terminal strip C (S-3). Connect the other lead of this capacitor to lug 1 of terminal strip C (S-1).
- ( ) Remove the two top nuts and lockwashers that hold the meter to the front panel.
- ( ) Fasten the top chassis in position as shown in Pictorial 3 by replacing these nuts and lockwashers, and tightening them.
- ( ) Mount terminal strips E, F, and G, using 6-32 x 1/4" screws, #6 lockwashers, and 6-32 nuts.
- ( ) Twist two 3" lengths of hookup wire together. At one end connect one wire to lug 4 (NS) and the other wire to lug 5 (NS) of tube socket V1.
- ( ) At the other end of this twisted pair of hookup wires, connect one wire to lug 4 (S-1) and connect the other wire to lug 5 (S-1) of tube socket V2.
- ( ) Connect a 3-1/2" length of hookup wire from lug 4 of terminal strip F (NS) to lug 2 of tube socket V2 (NS).
- ( ) R3. Connect a 47 K $\Omega$  (yellow-violet-orange) resistor from lug 1 (NS) to lug 2 (NS) of terminal strip D.
- ( ) C13. Connect the lead from the banded end of a .1  $\mu$ fd tubular capacitor to lug 1 of terminal strip F (NS). Connect the other lead of this capacitor to lug 4 of terminal strip F (S-2). Make sure this capacitor does not cover the chassis hole near the flange of the chassis.

## WIRING THE BOTTOM CHASSIS

Refer to Pictorial 4 for the following steps.

- ( ) Mount 9-pin tube sockets V1 and V2 as shown in Detail 4A. Use 3-48 x 1/4" screws, #3 lockwashers, and 3-48 nuts. Be sure to align the open spaces as shown.
- ( ) Connect a length of bare wire from lug 9 of tube socket V1 (S-1) to lug 1 of terminal strip F (NS).
- ( ) R16. Connect a 47 K $\Omega$  (yellow-violet-orange) resistor from lug 1 (S-3) to lug 2 (NS) of terminal strip F.
- ( ) R14. Connect a 470 K $\Omega$  (yellow-violet-yellow) resistor from lug 2 of terminal strip F (NS) to lug 8 of tube socket V1 (NS).
- ( ) R15. Connect a 470 K $\Omega$  (yellow-violet-yellow) resistor from lug 7 of tube socket V1 (NS) to lug 3 of terminal strip F (NS).
- ( ) C7. Cut the positive (+) lead of a 2  $\mu$ fd 150 volt electrolytic capacitor to a length of 1-1/4". Place 1" of sleeving over this lead and connect it to lug 8 of tube socket V1 (S-2).
- ( ) Cut the negative lead of this capacitor to the proper length and connect it to lug 1 of terminal strip G (NS). Use sleeving.

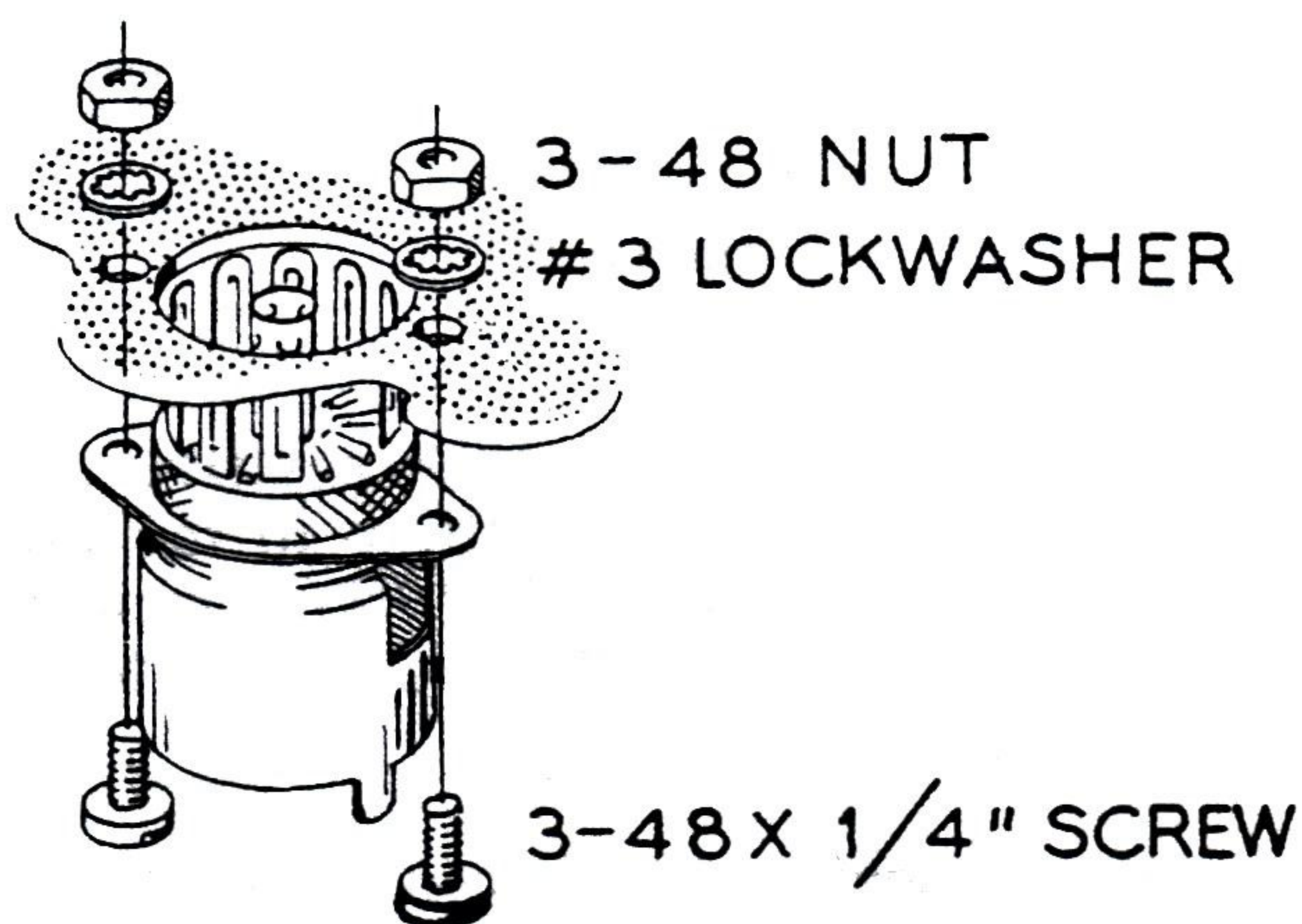

Detail 4A

- ( ) Mount 2-lug terminal strip D, using a 6-32 x 1/4" screw, #6 lockwashers, and a 6-32 nut. Install the #6 solder lug, facing as shown, under the screw on the other side of the chassis.

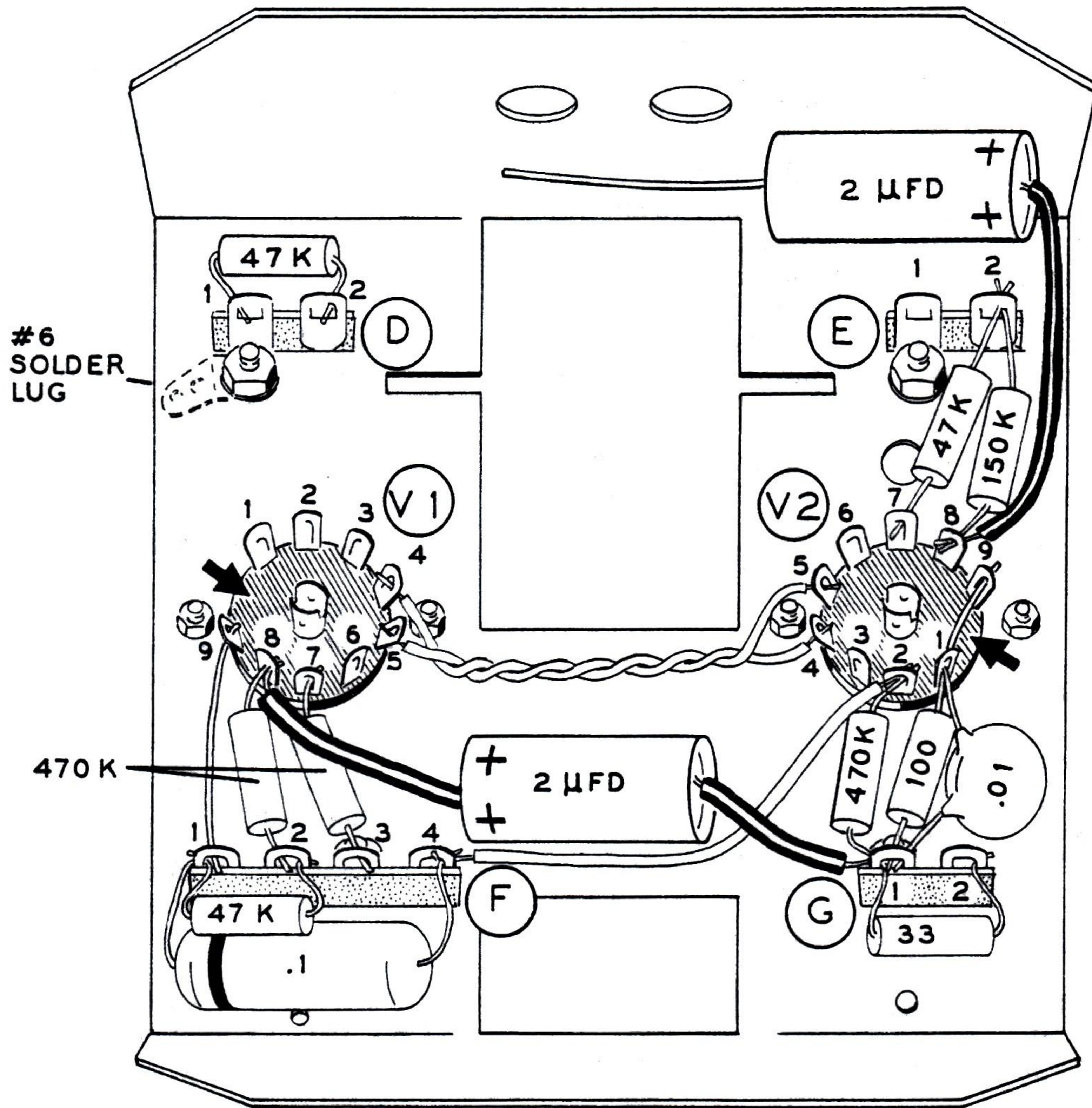

Pictorial 4.

- ( ) R24. Connect a 47 K $\Omega$  (yellow-violet-orange) resistor from lug 7 of tube socket V2 (NS) to lug 2 of terminal strip E (NS).
- ( ) R23. Connect a 150 K $\Omega$  (brown-green-yellow) resistor from lug 8 of tube socket V2 (NS) to lug 2 of terminal strip E (NS).
- ( ) C12. Cut the positive (+) lead of a 2  $\mu$ fd 150 volt electrolytic capacitor to a length of 1-3/4" and place 1-1/2" of sleeving over it. Connect this lead to lug 8 of tube socket V2 (S-2). Cut the other lead of this capacitor to a length of 3/4" and place the capacitor as shown in Pictorial 4. The other lead will be connected later.
- ( ) R19. Connect a 33  $\Omega$  (orange-orange-black) resistor from lug 1 (NS) to lug 2 (NS) of terminal strip G.
- ( ) R26. Insert one lead of a 100  $\Omega$  (brown-black-brown) resistor through lug 1 (NS) to lug 9 (S-1) of tube socket V2. Connect the other lead of this resistor to lug 1 of terminal strip G (NS).
- ( ) C14. Connect a .01  $\mu$ fd disc capacitor from lug 1 of tube socket V2 (S-3) to lug 1 of terminal strip G (NS).
- ( ) R25. Connect a 470 K $\Omega$  (yellow-violet-yellow) resistor from lug 2 of tube socket V2 (S-2) to lug 1 of terminal strip G (NS).

Refer to Pictorial 5 for the following steps.

- ( ) Fasten the bottom chassis to the front panel as shown in Detail 5A by installing the two binding posts at the bottom of the front panel. Place the solder lugs as shown. Be sure that the four prewired range switch components, the  $47\ \Omega$  resistor, the  $.02\ \mu\text{fd}$  disc capacitor, the  $.1\ \mu\text{fd}$  and the  $1\ \mu\text{fd}$  capacitors and the free end of the hookup wire are directed up through the large opening in the bottom chassis.
- ( ) Slightly spread the open end of the binding posts with a phillips screwdriver after the binding post caps have been screwed on. Tap the screwdriver lightly. This will keep the caps from falling off.

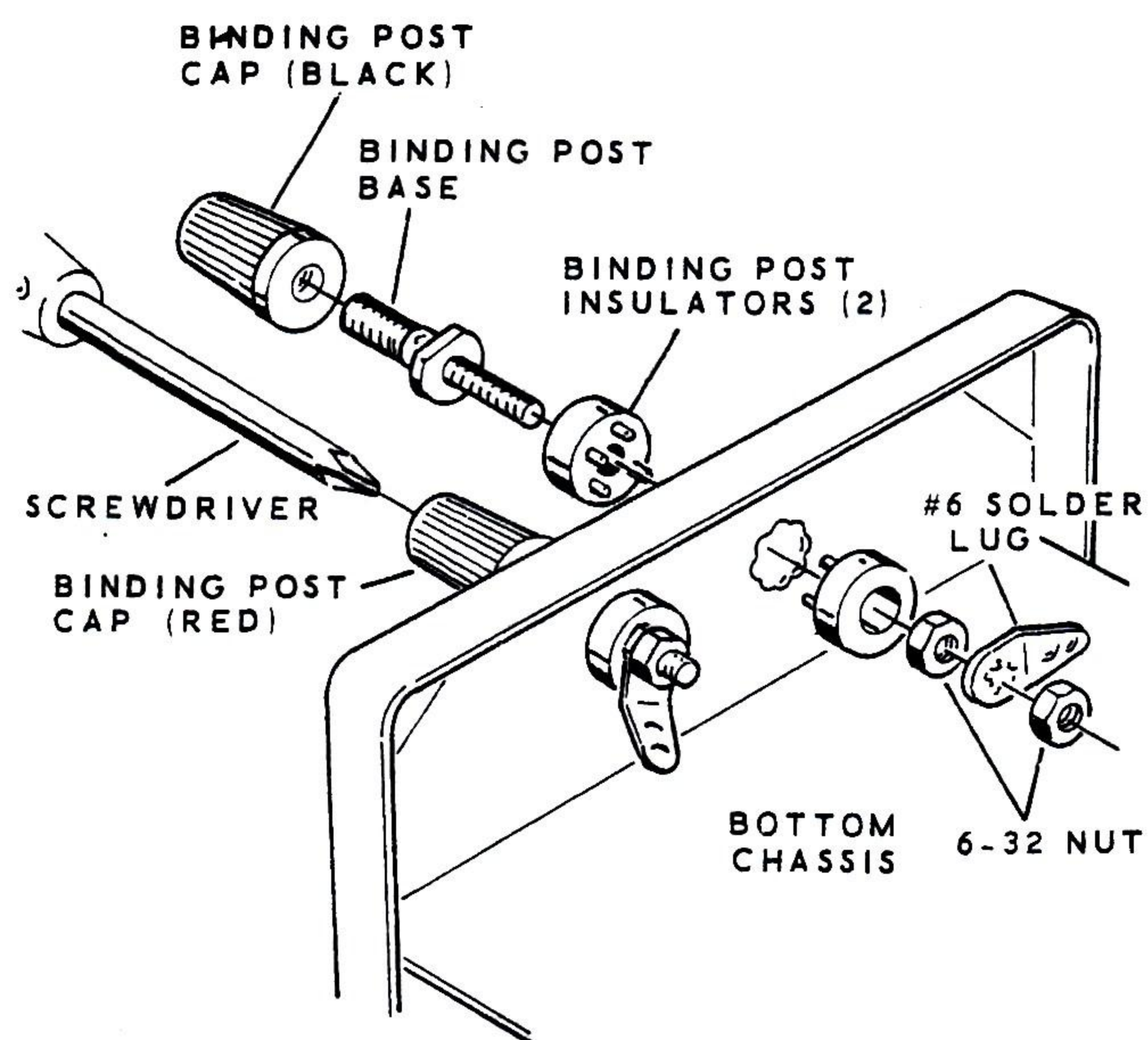

Detail 5A

**NOTE:** The switch shield will be inserted down through the long open slot between terminal strips D and E. Be sure that you do not wire any components across this open space since they would prevent the shield from being installed later.

- ( ) Connect the free lead of the  $1\ \mu\text{fd}$  mylar capacitor to lug 1 of tube socket V1 (NS). Place the body of the capacitor against the chassis as shown.
- ( ) Cut the free lead of the  $.1\ \mu\text{fd}$  tubular capacitor coming from the range switch to a length of  $1\text{-}1/2$ " and place  $1$ " of sleeving over it. Connect this lead to lug 7 of tube socket V1 (S-2).

- ( ) Place the body of the  $47\ \Omega$  resistor coming from the range switch close to terminal strip D as shown. Connect this lead to lug 2 of tube socket V1 (S-1).
- ( ) Connect the free lead of the  $.02\ \mu\text{fd}$  disc capacitor coming from the range switch to solder lug 1 of the input terminals (S-1).
- ( ) Connect the  $3/4$ " free lead of the  $2\ \mu\text{fd}$  150 volt electrolytic capacitor to solder lug 2 of the input terminals (NS).
- ( ) Connect a  $1$ " length of bare wire from solder lug 2 of the input terminals (S-2) to lug 1 of terminal strip E (NS).
- ( ) R7. Connect a  $10\ \text{K}\Omega$  (brown-black-orange) resistor from lug 1 of tube socket V1 (S-2) to lug 1 of terminal strip D (S-2).
- ( ) R5. Connect a  $470\ \text{K}\Omega$  (yellow-violet-yellow) resistor from lug 2 of terminal strip D (NS) to lug 3 of tube socket V1 (NS).
- ( ) Connect the hookup wire coming from lug 4 of deck A of the range switch to lug 2 of terminal strip D (S-3).
- ( ) Note the 3-conductor shielded cable and the twisted hookup wires coming from the grommet in the corner of the top chassis. Route these up behind the front panel and through the opening in the bottom chassis as shown.
- ( ) At the free end of the twisted pair of hookup wires that come from the top chassis connect one wire to lug 4 (S-2) and connect the other wire to lug 5 (S-2) of tube socket V1.
- ( ) Connect the shield of the 3-conductor cable to lug 1 of terminal strip E (S-2).
- ( ) Connect the black lead of the 3-conductor shielded cable to lug 2 of terminal strip E (S-3).
- ( ) Connect the white lead of the 3-conductor shielded cable to lug 3 of tube socket V1 (S-2).
- ( ) Connect the red lead of the 3-conductor shielded cable to lug 2 of terminal strip F (S-3).
- ( ) Install the 6-32 tapped spacer on the ground terminal binding post. See Detail 5B.

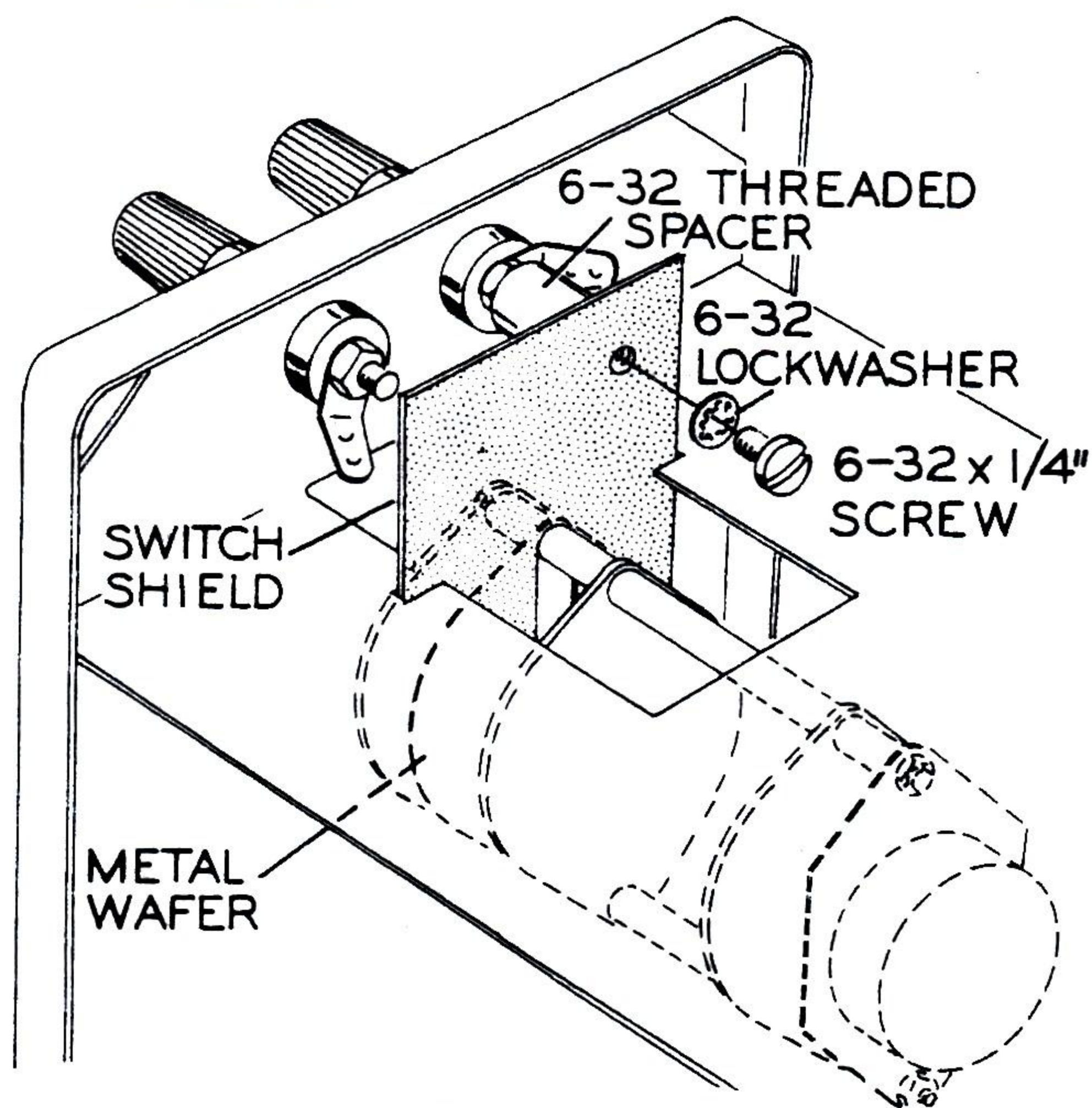

Detail 5B

- ( ) Install the switch shield as shown in Detail 5B. Place the slot in the switch shield over the mounting shaft of the range switch between the metal wafer and deck B. Fasten the switch shield to the threaded spacer with a 6-32 x 1/4" screw and a #6 lockwasher. Make sure that the shield does not touch any of the switch lugs or any bare wires to components.
- ( ) Cut one lead of a 1  $\mu$ fd mylar capacitor to a length of 3/4" and connect it to lug 4 of terminal strip A (S-3). See Detail 5C.
- ( ) Place a 1-3/4" length of sleeving over the remaining lead of this capacitor and insert

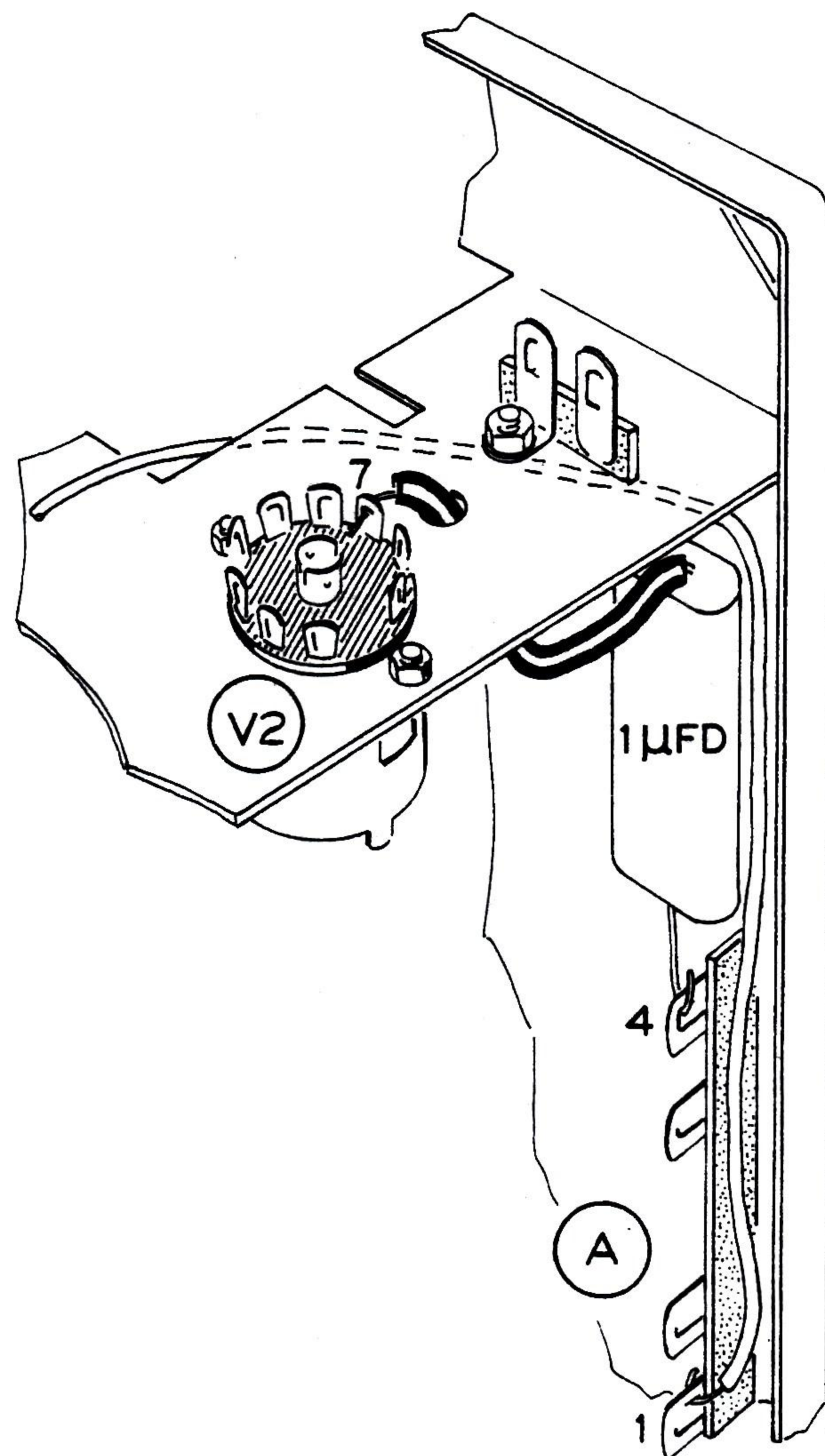

Detail 5C

it up through the hole in the chassis near lug 7 of V2. Now connect this lead to lug 7 of V2 (S-2). Be sure that capacitor is placed against the front panel.

- ( ) Route the 8" wire coming from lug 1 of terminal strip A up the side of the front panel and through the large hole in the bottom chassis as shown in Detail 5C.

Refer to Detail 5D for the following steps.

- ( ) Connect a 4-1/4" length of hookup wire from lug 1 of deck C on the range switch (S-2) to the ground lug near tube socket V1 (NS).
- ( ) Connect the negative lead of the 10  $\mu$ fd capacitor coming from lug 4 of deck A on the range switch to the ground lug near tube socket V1 (S-2).

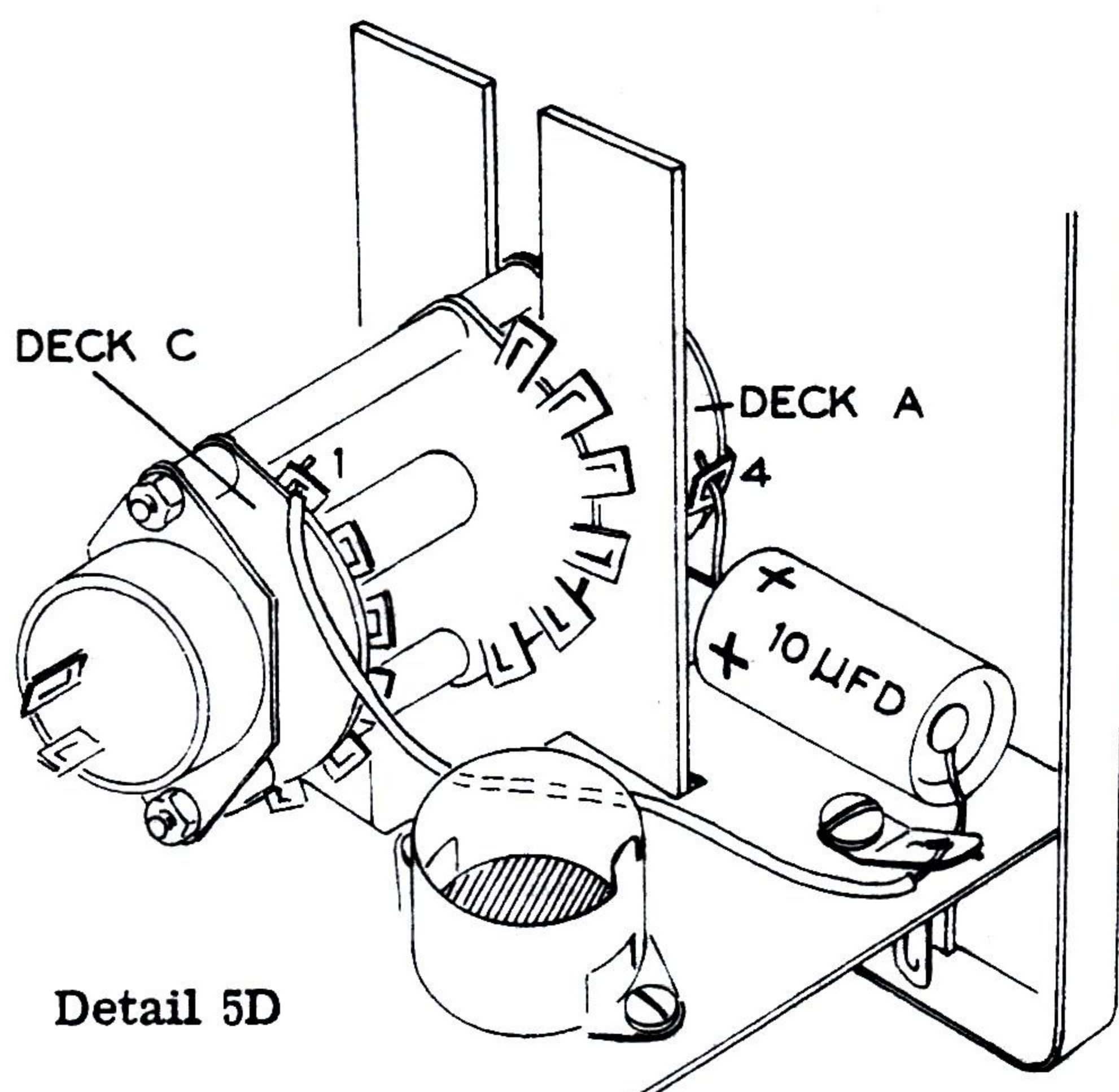

Detail 5D

## FINAL WIRING AND ASSEMBLY

Refer to Pictorial 6 for the following steps.

- ( ) Cut the black power transformer lead closest to terminal H to a length of 2". Connect this lead to terminal H (NS).
- ( ) Connect the other black power transformer lead to lug 2 of the ON-OFF switch (S-1).
- ( ) Mount the two speednuts on the back plate as shown in Detail 6A. Be sure that the correct side of the speednuts face toward you as shown in Pictorial 6.

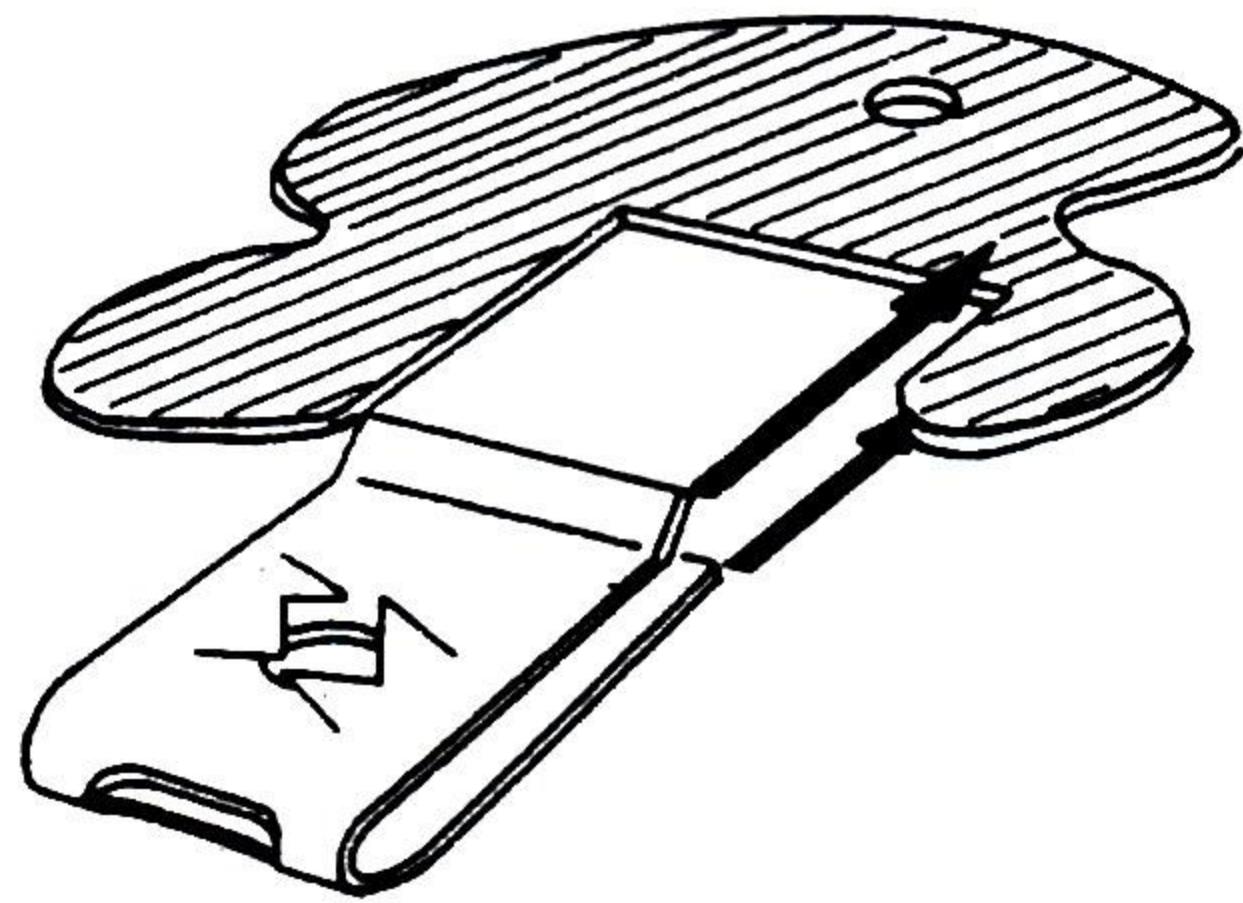

Detail 6A

- ( ) Mount the line cord on the back plate with the strain relief insulator as shown in Detail 6B. The insulator should be 3" from the end of the line cord.

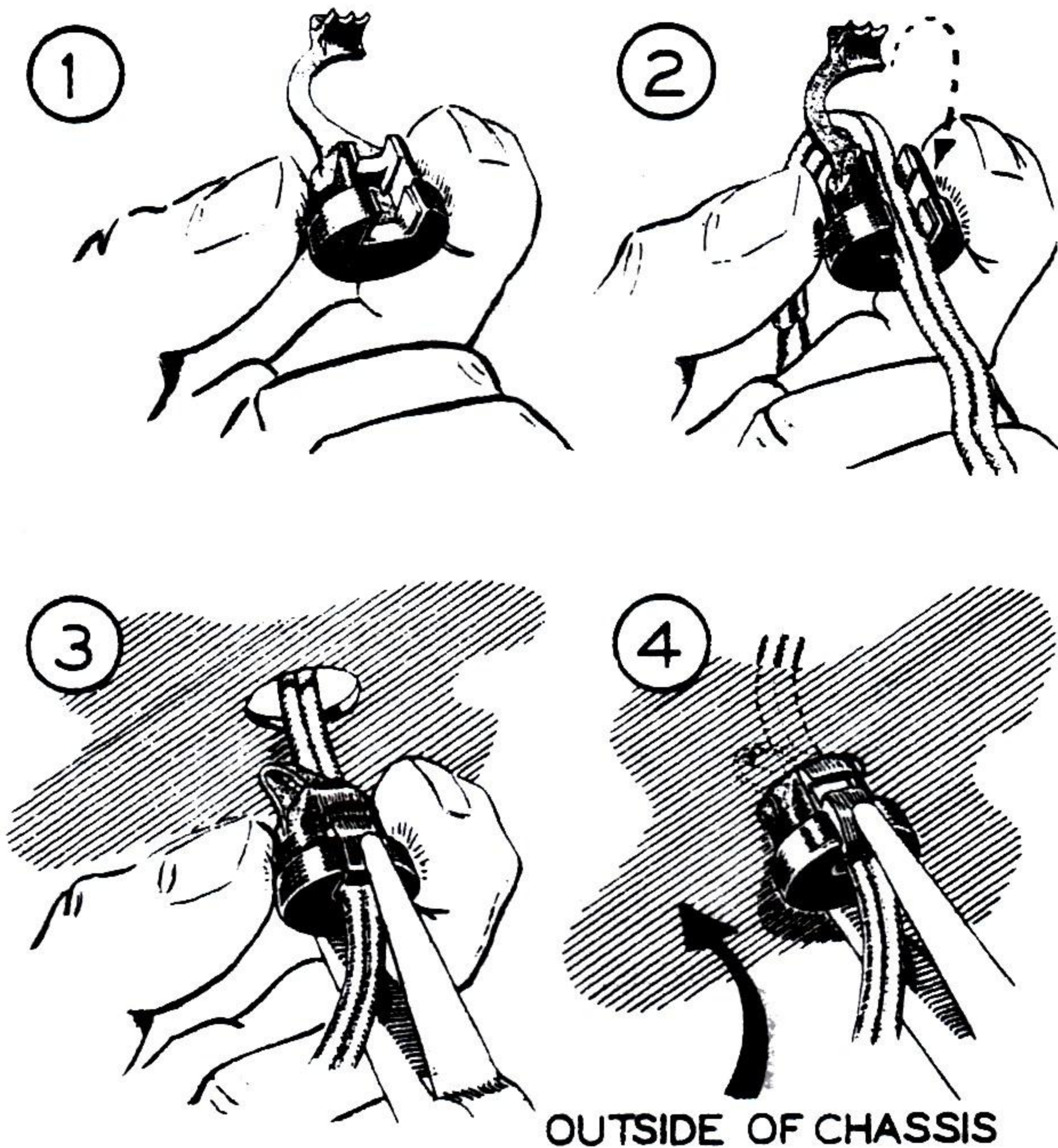

Detail 6B

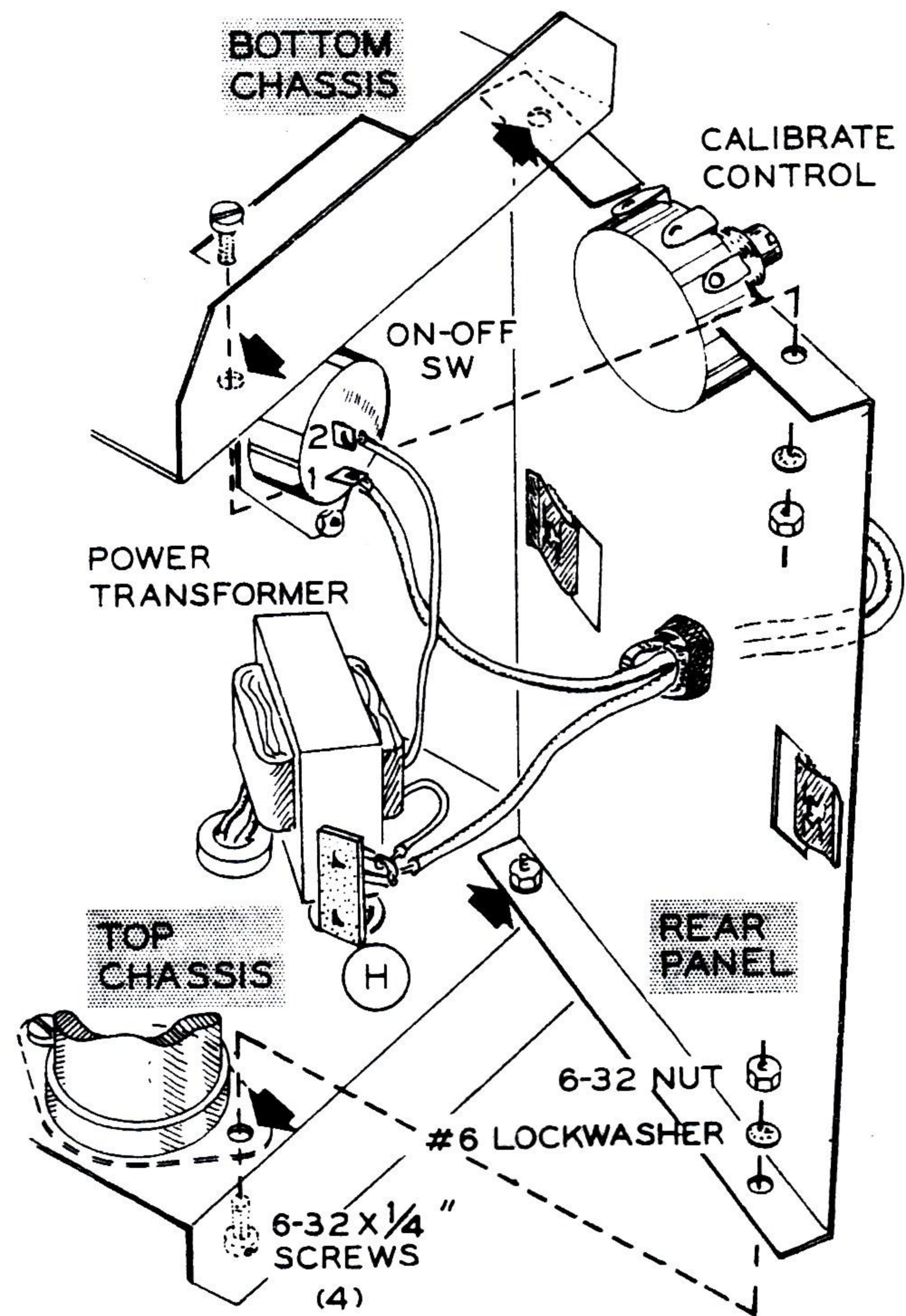

Pictorial 6

- ( ) Using a 6-32 x 1/4" screw, #6 lockwasher, and a 6-32 nut, fasten the corner of the rear panel loosely to the chassis as it appears in Pictorial 6.
- ( ) Connect one of the line cord leads to lug 1 of the ON-OFF switch (S-1). Connect the other line cord lead to terminal H (S-2).
- ( ) Install the 40 Ω control on the rear panel with a control lockwasher, control flat washer and control nut. Place the lugs of the control upward as they are shown.
- ( ) Fasten the rear panel in position between the top chassis and the bottom chassis, using 6-32 x 1/4" screws, #6 lockwashers, and 6-32 nuts. The bottom chassis will have to be raised slightly when installing the rear panel to pass the lugs of the 40 Ω control.

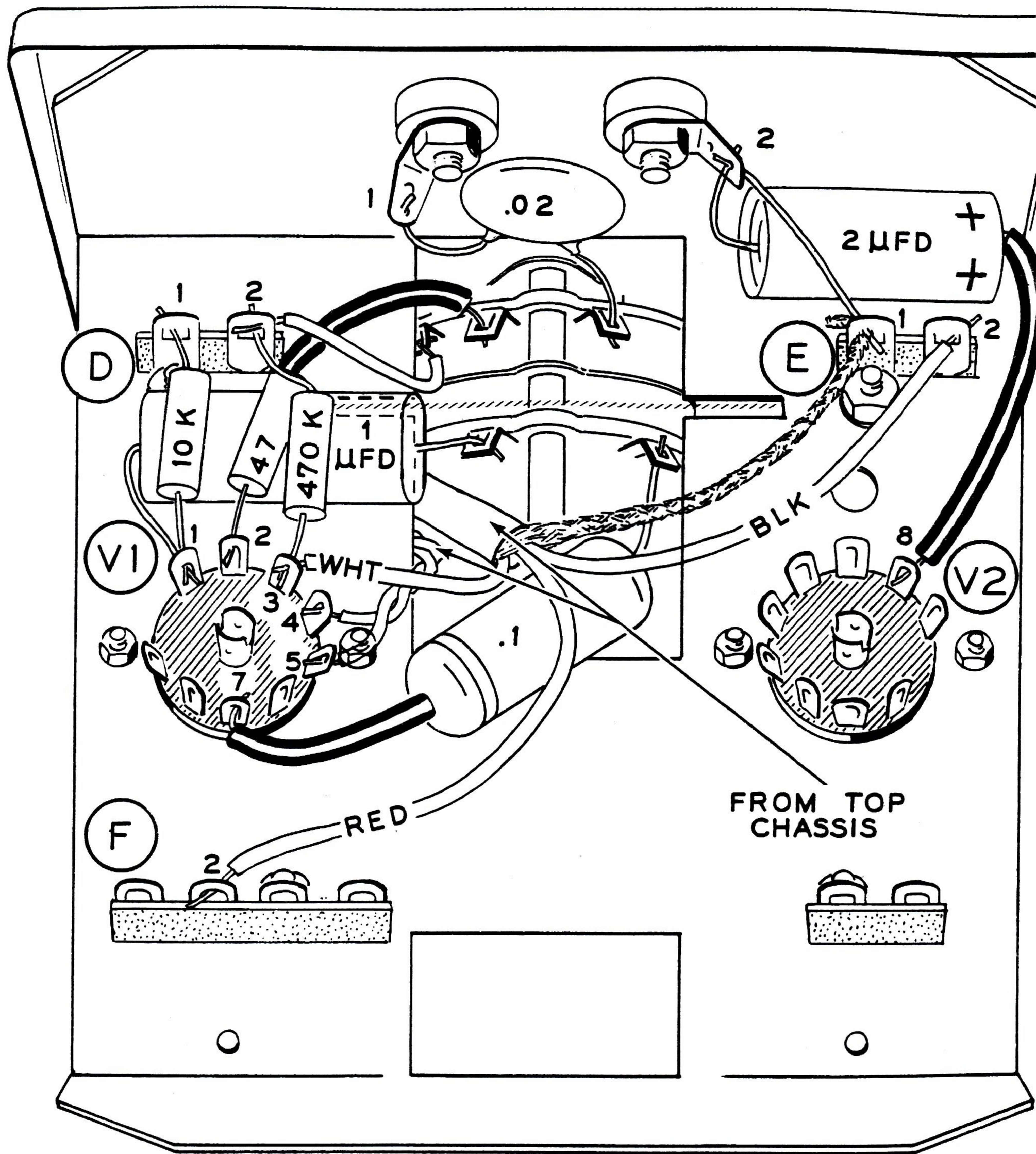

Pictorial 5

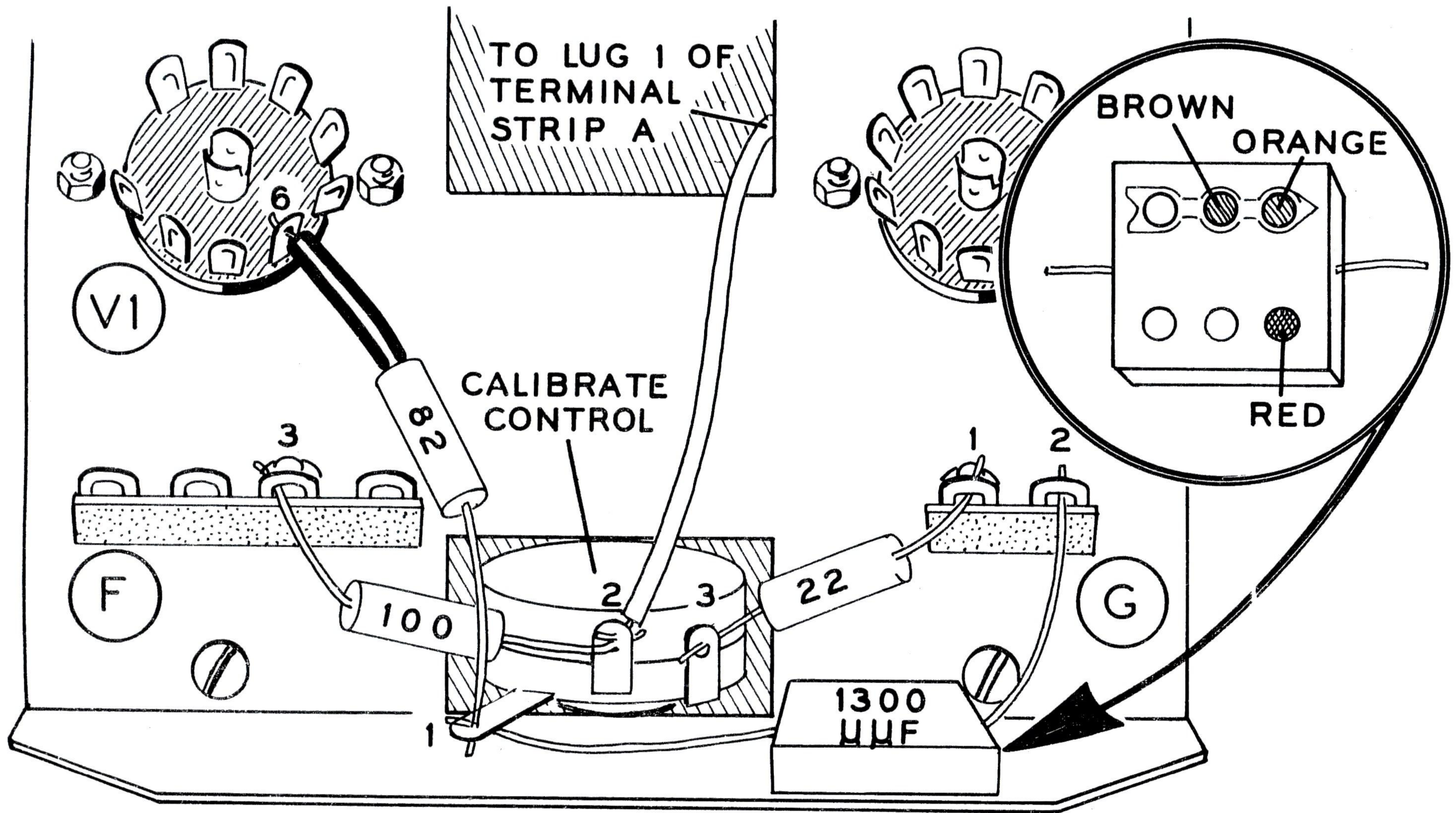

Pictorial 7

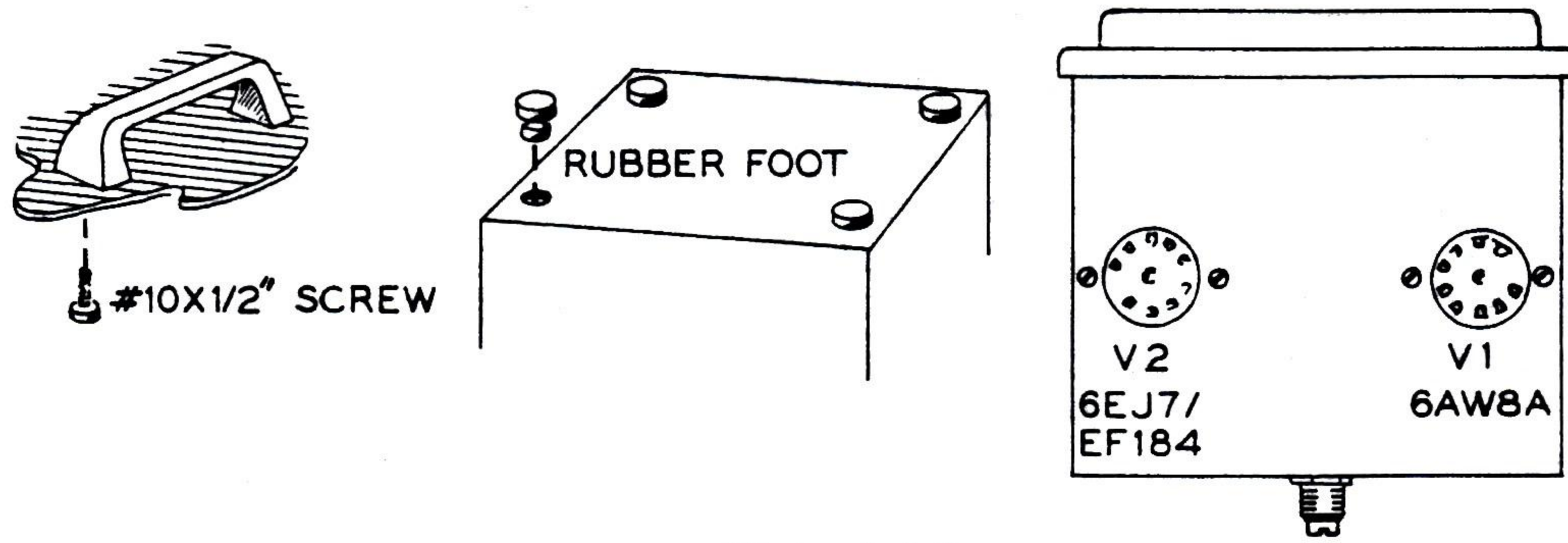

Pictorial 8

Refer to Pictorial 7 for the following steps.

- ( ) R20. Connect a 22  $\Omega$  (red-red-black) resistor from lug 3 of the calibrate control (S-1) to lug 1 of terminal strip G (S-6).
- ( ) Bend lug 1 of the calibrate control up as it is shown in the Pictorial.
- ( ) Connect the free end of the wire coming from lug 1 of terminal strip A to lug 2 of the calibrate control (NS).
- ( ) R27. Connect a 100  $\Omega$  (brown-black-brown) resistor from lug 3 of terminal strip F (S-2) to lug 2 of the calibrate control (S-2).
- ( ) C9. Connect a 1300  $\mu\mu\text{f}$  mica capacitor from lug 1 of the calibrate control (NS) to lug 2 of terminal strip G (S-2).
- ( ) R17. Connect an 82  $\Omega$  (gray-red-black) resistor from lug 6 of tube socket V1 (S-1) to lug 1 of the calibrate control (S-2). Use sleeving.
- ( ) Carefully peel away the backing paper from the blue and white identification label. Then press the label onto the rear of the cabinet (or chassis). Be sure to refer to the numbers on this label in any communications you have with the Heath Company about this kit.

This completes wiring. All connections should now have been soldered. Lugs 3 and 6 on socket V2 are unused.

Refer to Pictorial 8 for the following steps.

- ( ) Install the handle at the top of the cabinet, using the two #10 x 1/2" handle screws.
- ( ) Install the four rubber feet in the four holes on the bottom of the cabinet.
- ( ) Install the tubes in their sockets; V1-6AW8, V2-6EJ7/EF184. Install a tube shield on each tube socket.
- ( ) Strip both ends of the lengths of black and red test lead. Prepare each of the test leads as shown in Figure 1.
- ( ) Fasten an alligator clip at one end of the red test lead. Install the red banana plug sleeve over the other end with the threaded end of the sleeve facing outward.
- ( ) Fasten the banana plug on the end of the test lead, and screw the banana plug sleeve onto the banana plug.
- ( ) Prepare the black test lead in the same manner.

Your VTVM is now ready for calibration.

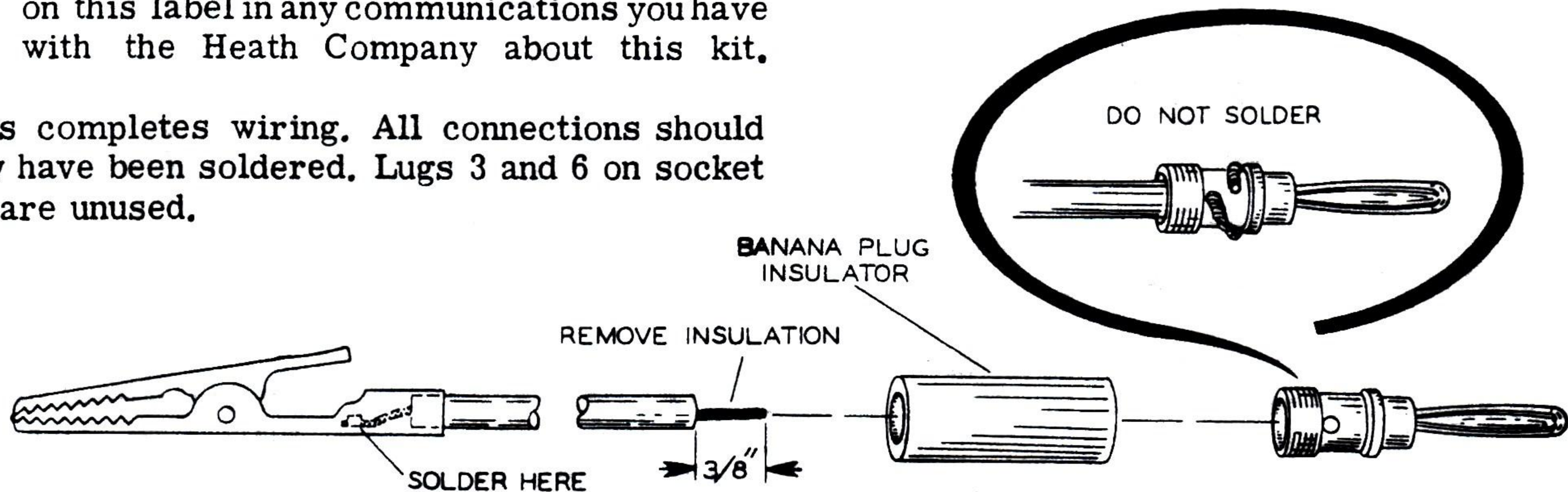

Figure 1

## ADJUSTMENTS

For maximum accuracy, use an accurate AC voltmeter, and/or an accurate AC voltage source to calibrate your VTVM. If these are not available, you can make an approximate calibration by using your 117 volt power line voltage as a calibrating source.

### LINE VOLTAGE CALIBRATION

- ( ) Before turning the VTVM on, adjust the meter needle to be exactly over zero on the front panel by turning the small screw near the bottom center section of the meter face.
- ( ) Turn on your VTVM by turning the range switch to the 300 volt range. Allow it to operate for fifteen minutes for a thorough warmup period. If the filaments do not light or if any indication of malfunction appears, turn the unit off immediately and refer to the In Case Of Difficulty section.
- ( ) Connect the test leads of the VTVM to the 117 volt power line.

(CAUTION: A 117 volt line is dangerous. Proceed with care. Hold only one lead at a time.)

- ( ) Adjust the calibrate control so the meter needle indicates 117 volts. Disconnect the leads from the 117 volt power line.
- ( ) Turn the trimmer capacitor (on the range switch) to the position shown in Figure 2. This compensates the input voltage divider approximately for frequencies throughout the range of the VTVM.

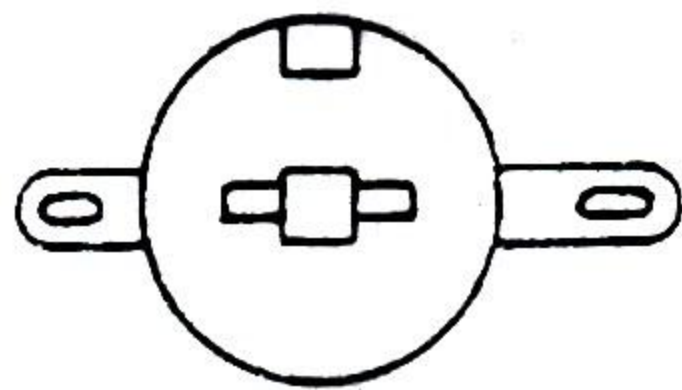

Figure 2

### INSTRUMENT CALIBRATION

Use an AC voltmeter of known accuracy, and an audio signal generator.

- ( ) Turn the VTVM on by turning the range switch to the 3 volt range. Allow the unit to warm up for fifteen minutes. If the fila-

ments do not light or if any indication of malfunction appears, turn the unit off immediately and refer to the In Case Of Difficulty section.

- ( ) Place the VTVM in its cabinet, but do not secure in place.
- ( ) Set the frequency of the signal generator to 1000 cps. Set the output of the signal generator to 3 volts, as measured with the standard meter.
- ( ) Now connect the test leads of the IM-21 VTVM to the output of the signal generator.
- ( ) Adjust the calibrate control so that the meter indicates 3 volts.
- ( ) Remove the cabinet from the VTVM.
- ( ) Turn the range switch to the 10 volt range and adjust the trimmer capacitor (on the range switch) so that the meter indicates exactly 3 volts.

This completes the adjustment.

- ( ) Install the VTVM in the cabinet, using two 6-32 x 1/2" screws as shown in Figure 3.

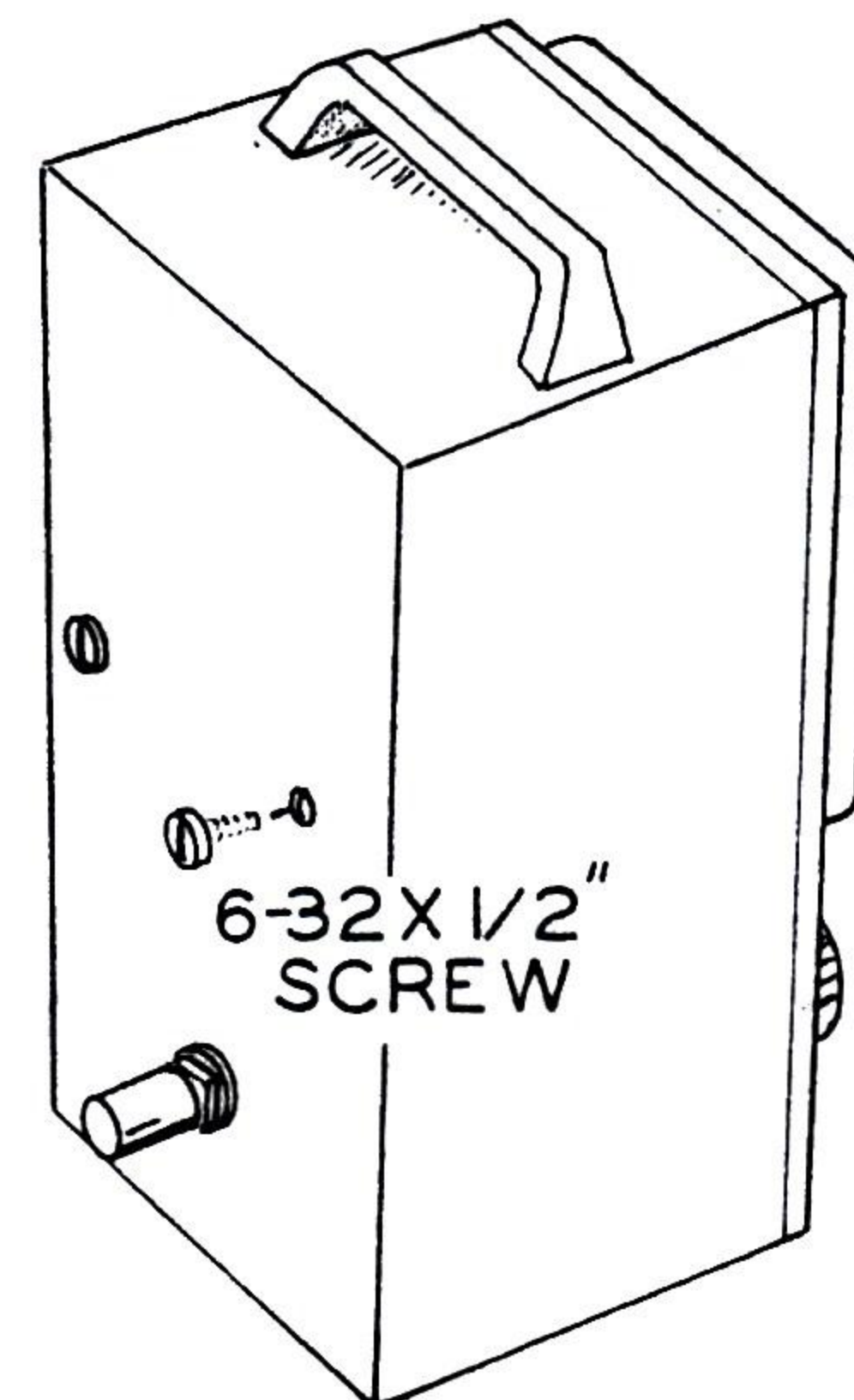

Figure 3

NOTE: Be very careful, when you install or remove the plastic control guard, that you do not change the setting of the calibrate control.

- ( ) Install the plastic control guard on the calibration control.

## OPERATION

The OFF position of the range switch is just above the highest voltage range. This protects the instrument by insuring that it is always turned to the highest voltage range when first turned on. On the lower ranges, the meter may indicate some voltage when no connections are made to the input terminals. This residual voltage is caused by the extreme sensitivity of the instrument. Reverse the AC line plug to determine which way gives the lowest residual voltage.

The range switch positions cover the 300, 100, 30, 10, 3, 1, .3, .1, .03, and .01 volt ranges. The meter scale is marked 0-3 and 0-10 for voltage measurements. Be sure to place the decimal in the proper place in order to indicate the correct voltage for each range.

Example 1: Using the .03 range, the meter reads 2. Move the decimal point two places to the left for the correct voltage; in this case .02 volt.

Example 2: The meter reads 6.4 on the .1 volt range. Move the decimal point two places to the left for the correct voltage; in this case .064 volt.

The decibel (db) scales range from -40 db to +50 db. When reading the db scale, add the meter reading to the range indication.

Example 1: The meter indicates -5 db and the range switch is on the +20 db range; the actual value is +15 db.

Example 2: The meter indicates -4 db and the range switch is turned to the -10 db position; the actual value is -14 db.

Do not touch the input terminals when the range switch is set to one of the low ranges. Stray electric fields picked up by the human body will deflect the pointer beyond full scale, causing the meter pointer to bang against the limit pin. Repeated extreme overloads could bend the pointer.

Although the pointer can be bent by repeated extreme overloads, the electronic circuit limits the signal applied to the meter to a safe value, thus protecting the coil windings of the meter from being damaged. NOTE: Occasionally, switching transients will cause the meter to deflect to full scale when switching from one range to another. These transients are normal, and will not harm the meter.

## APPLICATIONS

Almost any type of AC voltage, filament voltage, power line voltage, noise voltage, or even output or gain measurements can be made quickly and accurately with your AC VTVM. It is calibrated to read the root-mean-square (rms) value of a pure sine wave. This is 70.7% of the peak voltage.

### COMPLEX WAVEFORMS

As in most rectifier-type AC VTVMs, meter deflection is proportional to the average value of the input waveform. When measuring odd-shaped waveforms (square waves, sawtooth waves or pulses) the meter reading must be given special interpretation. Special reading material on this subject will be found listed in the Bibliography.

### READING DB

Since a power level in a circuit with a fixed impedance varies with the square of the voltage, the voltage reading is indicative of the power level. Therefore, a voltmeter can be calibrated with a db scale, which provides a convenient method of measuring power loss or gain.

Basically, the db is defined as follows:

$$\text{db} = 10 \log \frac{P_1}{P_2} = 10 \log \frac{\left(\frac{E_1}{R}\right)^2}{\left(\frac{E_2}{R}\right)^2} = 10 \log \frac{(E_1)^2}{(E_2)^2} = 20 \log \frac{(E_1)}{(E_2)}$$

Being logarithmic, it parallels to some extent the human impression of light and sound intensities. Thus a change in signal level of a number of db will give the same impression regardless of the nominal operating level, although

the change in power may be milliwatts (for low level signals) or tens of watt (for high level signals).

Since the decibel only indicates a ratio between two power levels, it is not normally referenced to any definite level. The term dbm, decibels related to 1 milliwatt, came into use so that decibels could indicate a definite level as well as a ratio. This VTVM is calibrated to read directly in dbm when connected across a 600  $\Omega$  load. (0 dbm equals 1 milliwatt into a 600  $\Omega$  load.)

### CIRCUIT IMPEDANCES

Circuit impedances should be considered when comparing one db level to another. An example of

this could be where the gain of an amplifier is being measured. If the input impedance is the same as the output impedance, the db gain can be measured directly with the VTVM. If the input and output impedances are different, it is necessary to adjust each reading mathematically to a common reference level.

### VU APPLICATIONS

Because of the VU-type ballistics (rapid action) of the meter movement, the VTVM can be used to indicate changing AC voltages such as those that occur in speech or music. This enables you to use the VTVM to monitor audio signals, such as the input to a tape recorder, in order to insure proper recording level.

## BIBLIOGRAPHY

Langford-Smith, RADIOTRON DESIGNERS HANDBOOK, 4th Edition, Chapter 19, Published by RCA.

Rider, J.F., VACUUM TUBE VOLTMETER, 2nd Edition.

Turner, BASIC ELECTRONIC TEST INSTRUMENTS, Rinehart, 1953.

HEWLETT-PACKARD Journal, ARTICLES ON WAVEFORM, April-May-June 1955, Vol. 6, Numbers 8, 9, and 10.

## IN CASE OF DIFFICULTY

1. Recheck the wiring. Trace each lead in colored pencil on the Pictorial as it is checked. It is frequently helpful to have a friend check your work. Someone who is not familiar with the unit may notice something consistently overlooked by the constructor.
2. It is interesting to note that about 90% of the kits that are returned for repair, do not function properly due to poor connections and soldering. Therefore, many troubles can be eliminated by reheating all connections to make sure that they are soldered as described in the Proper Soldering Techniques section of this manual.
3. Check to be sure that both tubes are in their proper locations. Make sure that they light up properly.
4. Check for bits of solder, wire ends or other foreign matter which may be lodged in the wiring.
5. Check the values of the component parts. Be sure that the proper part has been wired into the circuit, as shown in the pictorial diagrams and as called out in the wiring instructions.
6. Check the tubes with a tube tester or by substitution of tubes of the same types which are known to be good.
7. If, after careful checks, the trouble is still not located and a voltmeter is available, check voltage readings against those found on the Schematic Diagram. NOTE: All voltage readings were taken with an 11 megohm input vacuum tube voltmeter. Voltages may vary as much as 10% due to line voltage variations. Larger variations may lead you to the cause of the trouble.
8. A review of the Circuit Description will prove helpful in indicating where to look for the cause of the trouble.



## SERVICE INFORMATION

### SERVICE

If, after applying the information contained in this manual and your best efforts, you are still unable to obtain proper performance, it is suggested that you take advantage of the technical facilities which the Heath Company makes available to its customers.

The Technical Consultation Department is maintained for your benefit. This service is available to you at no charge. Its primary purpose is to provide assistance for those who encounter difficulty in the construction, operation or maintenance of HEATHKIT equipment. It is not intended, and is not equipped to function as a general source of technical information involving kit modifications nor anything other than the normal and specified performance of HEATHKIT equipment.

Although the Technical Consultants are familiar with all details of this kit, the effectiveness of their advice will depend entirely upon the amount and the accuracy of the information furnished by you. In a sense, YOU MUST QUALIFY for GOOD technical advice by helping the consultants to help you. Please use this outline:

1. Before writing, fully investigate each of the hints and suggestions listed in this manual under In Case Of Difficulty. Possibly it will not be necessary to write.
2. When writing, clearly describe the nature of the trouble and mention all associated equipment. Specifically report operating procedures, switch positions, connections to other units and anything else that might help to isolate the cause of trouble.
3. Report fully on the results obtained when testing the unit initially and when following the suggestions under In Case Of Difficulty. Be as specific as possible and include voltage readings if test equipment is available.
4. Identify the kit Model Number and Series Number, and date of purchase, if available. Also mention the date of the kit assembly manual. (Date at bottom of Page 1.)
5. Print or type your name and address, preferably in two places on the letter.

With the preceding information, the consultant will know exactly what kit you have, what you would like it to do for you and the difficulty you wish to correct. The date of purchase tells him whether or not engineering changes have been made since it was shipped to you. He will know what you have done in an effort to locate the cause of trouble and, thereby, avoid repetitious suggestions. In short, he will devote full time to the problem at hand, and through his familiarity with the kit, plus your accurate report, he will be able to give you a complete and helpful answer. If replacement parts are required, they will be shipped to you, subject to the terms of the Warranty.

The Factory Service facilities are also available to you, in case you are not familiar enough with electronics to provide our consultants with sufficient information on which to base a diagnosis of your difficulty, or in the event that you prefer to have the difficulty corrected in this manner. You may return the completed instrument to the Heath Company for inspection and necessary repairs and adjustments. You will be charged a minimal service fee, plus the price of any additional parts or material required. However, if the completed kit is returned within the Warranty period, parts charges will be governed by the terms of the Warranty. State the date of purchase, if possible.

Local Service by Authorized HEATHKIT Service Centers is also available in some areas and often will be your fastest, most efficient method of obtaining service. HEATHKIT Service Centers will honor the regular 90 day HEATHKIT Parts Warranty on all kits, whether purchased through a dealer or directly from the Heath Company; however, it will be necessary that you verify the purchase date of your kit.

Under the conditions specified in the Warranty, replacement parts are supplied without charge; however, if the Service Center assists you in



locating a defective part (or parts) in your kit, or installs a replacement part for you, you may be charged for this service.

HEATHKIT equipment purchased locally and returned to Heath Company for service must be accompanied by your copy of the dated sales receipt from your authorized HEATHKIT dealer in order to be eligible for parts replacement under the terms of the Warranty.

**THIS SERVICE POLICY APPLIES ONLY TO COMPLETED EQUIPMENT CONSTRUCTED IN ACCORDANCE WITH THE INSTRUCTIONS AS STATED IN THE MANUAL.** Equipment that has been modified in design will not be accepted for repair. If there is evidence of acid core solder or paste fluxes, the equipment will be returned NOT repaired.

For information regarding modification of HEATHKIT equipment for special applications, it is suggested that you refer to any one or more of the many publications that are available on all phases of electronics. They can be obtained at or through your local library, as well as at most electronic equipment stores. Although the Heath Company sincerely welcomes all comments and suggestions, it would be impossible to design, test, evaluate and assume responsibility for proposed circuit changes for special purposes. Therefore, such modifications must be made at the discretion of the kit builder, using information available from sources other than the Heath Company.

## REPLACEMENTS

Material supplied with HEATHKIT products has been carefully selected to meet design requirements and ordinarily will fulfill its function without difficulty. Occasionally improper instrument operation can be traced to a faulty component. Should inspection reveal the necessity for replacement, write to the Heath Company and supply all of the following information.

- A. Thoroughly identify the part in question by using the part number and description found in the manual Parts List.
- B. Identify the kit Model Number and Series Number.

C. Mention date of purchase.

D. Describe the nature of defect or reason for requesting replacement.

The Heath Company will promptly supply the necessary replacement. PLEASE DO NOT RETURN THE ORIGINAL COMPONENT UNTIL SPECIFICALLY REQUESTED TO DO SO. Do not dismantle the component in question as this will void the guarantee. This replacement policy does not cover the free replacement of parts that may have been broken or damaged through carelessness on the part of the kit builder.

## SHIPPING INSTRUCTIONS

In the event that your instrument must be returned for service, these instructions should be carefully followed.

ATTACH A TAG TO THE EQUIPMENT BEARING YOUR NAME, COMPLETE ADDRESS, DATE OF PURCHASE, AND A BRIEF DESCRIPTION OF THE DIFFICULTY ENCOUNTERED. Wrap the equipment in heavy paper, exercising care to prevent damage. Place the wrapped equipment in a stout carton of such size that at least three inches of shredded paper, excelsior, or other resilient packing material can be placed between all sides of the wrapped equipment and the carton. Close and seal the carton with gummed paper tape, or alternately, tie securely with stout cord. Clearly print the address on the carton as follows:

To: HEATH COMPANY  
Benton Harbor, Michigan 49022

Include your name and return address on the outside of the carton. Preferably affix one or more "Fragile" or "Handle With Care" labels to the carton, or otherwise so mark with a crayon of bright color. Ship by insured parcel post or prepaid express; note that a carrier cannot be held responsible for damage in transit if, in HIS OPINION, the article is inadequately packed for shipment.



## WARRANTY

The Heath Company warrants that the parts supplied in its kits (except batteries) shall be free of defects in materials and workmanship under normal conditions of use and service. The obligation of Heath under this warranty is limited to replacing or repairing any such part upon verification that it is defective in this manner. This obligation is further limited to such defective parts for which Heath is notified of the defect within a period of ninety (90) days from the original date of shipment of the kit.

The obligation of Heath under this warranty does not include either the furnishing or the expense of any labor in connection with the installation of such repaired or replacement parts. The obligation of Heath with respect to transportation expenses is limited to the cost of shipping the repaired or replacement parts to the buyer, provided such repair or replacement comes within the terms of this warranty.

The foregoing warranty extends only to the original buyer and is expressly in lieu of all other warranties, expressed or implied. The foregoing warranty is further in lieu of all other obligations or liabilities on the part of Heath and in no event shall the Heath Company be liable for any anticipated profits, consequential damages, loss of time or other losses incurred by the buyer in connection with the purchase, assembly or use of the kit product or components thereof.

The foregoing warranty shall be deemed completely void if acid core solder or paste flux or other corrosive solders or fluxes have been used in assembling or repairing the kit product. Heath will not replace or repair any parts of any kit products in which such corrosive solders or fluxes have been used.

This warranty applies only to Heath products sold and shipped to points within the continental United States and to APO and FPO shipments. Warranty replacement for Heath products sold or shipped outside the United States is on an f.o.b. factory basis. Contact the Heath authorized distributor in your country or write: Heath Company, International Division, Benton Harbor, Michigan, U.S.A.

**HEATH COMPANY**

## REPLACEMENT PARTS PRICE LIST

PART No.	PRICE Each	DESCRIPTION	PART No.	PRICE Each	DESCRIPTION
<b>RESISTORS</b>			<b>BINDING POSTS-TERMINALS</b>		
1-49	.10	22 $\Omega$ 1/2 watt	70-5	.10	Banana plug sleeve, black
1-103	.10	33 $\Omega$ 1/2 watt	70-6	.10	Banana plug sleeve, red
1-1	.10	47 $\Omega$ 1/2 watt	75-17	.10	Binding post insulator
1-118	.10	82 $\Omega$ 1/2 watt	100-16-2	.10	Binding post cap, black
1-3	.10	100 $\Omega$ 1/2 watt	100-16-18	.10	Binding post cap, red
1-13	.10	2700 $\Omega$ 1/2 watt	427-3	.15	Binding post base
1-20	.10	10 K $\Omega$ 1/2 watt	431-5	.10	4-lug terminal strip
1-25	.10	47 K $\Omega$ 1/2 watt	431-12	.10	4-lug terminal strip
1-60	.10	69 K $\Omega$ 1/2 watt	431-14	.10	2-lug terminal strip
1-27	.10	150 K $\Omega$ 1/2 watt	431-16	.10	2-lug terminal strip
1-33	.10	470 K $\Omega$ 1/2 watt	431-40	.10	4-lug terminal strip
2-159	.20	100 $\Omega$ precision	431-50	.10	1-lug terminal strip
2-25	.20	216.2 $\Omega$ precision	438-13	.20	Banana plug
2-28	.20	683.8 $\Omega$ precision			
2-31	.20	2162 $\Omega$ precision			
2-33	.20	6838 $\Omega$ precision			
2-39	.20	21.62 K $\Omega$ precision			
2-17	.40	10 megohm precision			
2-50	.20	10 K $\Omega$ precision			
<b>CAPACITORS</b>			<b>HARDWARE</b>		
20-71	.35	.0013 $\mu$ fd mica (1300 $\mu\mu$ f)	250-56	.05	6-32 x 1/4" screw
20-75	.70	.005 $\mu$ fd mica (5000 $\mu\mu$ f)	250-48	.05	6-32 x 1/2" screw
21-47	.15	.01 $\mu$ fd disc ceramic	250-49	.05	3-48 x 1/4" screw
21-31	.10	.02 $\mu$ fd disc ceramic	250-83	.05	#10 x 1/2" handle screw
23-28	.20	.1 $\mu$ fd tubular	250-89	.05	6-32 x 3/8" screw
27-19	1.50	1 $\mu$ fd Mylar	252-1	.05	3-48 nut
25-39	.60	2 $\mu$ fd 150 volt electrolytic	252-3	.05	6-32 nut
25-95	.50	10 $\mu$ fd electrolytic, 25 volts	252-7	.05	Control nut
25-23	1.25	20-40-80 $\mu$ fd electrolytic, 150 volts	440-11	.10	Plastic control guard
31-13	.90	3-12 $\mu\mu$ f trimmer	252-22	.05	6-32 speednut
<b>CONTROL-SWITCH-TRANSFORMER</b>			253-10	.05	Flat control washer
11-16	1.15	40 $\Omega$ control	254-1	.05	#6 lockwasher
63-283	3.40	Range switch, 11-position	254-4	.05	Control lockwasher
54-2	2.20	Power transformer	254-7	.05	#3 lockwasher
			255-17	.20	6-32 tapped spacer
			259-1	.05	#6 solder lug
			260-1	.15	Alligator clip



<u>PART No.</u>	<u>PRICE Each</u>	<u>DESCRIPTION</u>
<b>WIRE-SLEEVING</b>		
89-1	.35	Line cord
340-8	.05/ft	Bare wire
341-1	.05/ft	Black test lead
341-2	.05/ft	Red test lead
344-59	.05/ft	Hookup wire
346-1	.05/ft	Sleeving
346-6	.05/ft	3/8" sleeving
347-9	.10/ft	3-conductor shielded cable

<u>PART No.</u>	<u>PRICE Each</u>	<u>DESCRIPTION</u>
<b>TUBES-LAMP-SOCKETS</b>		
411-96	1.80	6AW8 tube
411-160	1.80	6EJ7/EF184 tube
412-1	.15	#47 lamp
434-43	.20	9-pin tube socket
434-44	.15	Pilot lamp socket

<u>PART No.</u>	<u>PRICE Each</u>	<u>DESCRIPTION</u>
<b>SHEET METAL PARTS</b>		
200-309	.50	Top chassis
200-310	.65	Bottom chassis
203-105-2	.90	Front panel
205-316	.45	Back plate
206-179	.15	Switch shield
90-180	3.15	Cabinet

<u>PART No.</u>	<u>PRICE Each</u>	<u>DESCRIPTION</u>
<b>MISCELLANEOUS</b>		
56-26	.30	Crystal diode
57-27	.60	Silicon rectifier
73-1	.10	Rubber grommet
206-54	.30	9-pin tube shield
211-15	.20	Handle
75-24	.10	Strain relief insulator
261-4	.05	Rubber feet
407-85	10.40	Meter
462-187	.30	Knob
481-1	.10	Capacitor mounting wafer
331-6	.10	Solder
595-455	2.00	Manual

The above prices apply only on purchases from the Heath Company where shipment is to a U.S.A. destination. Selling prices elsewhere in U.S.A. may be slightly higher to offset transportation and local taxes. Outside the U.S.A. parts and service are available from your local Heathkit source and will reflect additional transportation, taxes, duties and rates of exchange.

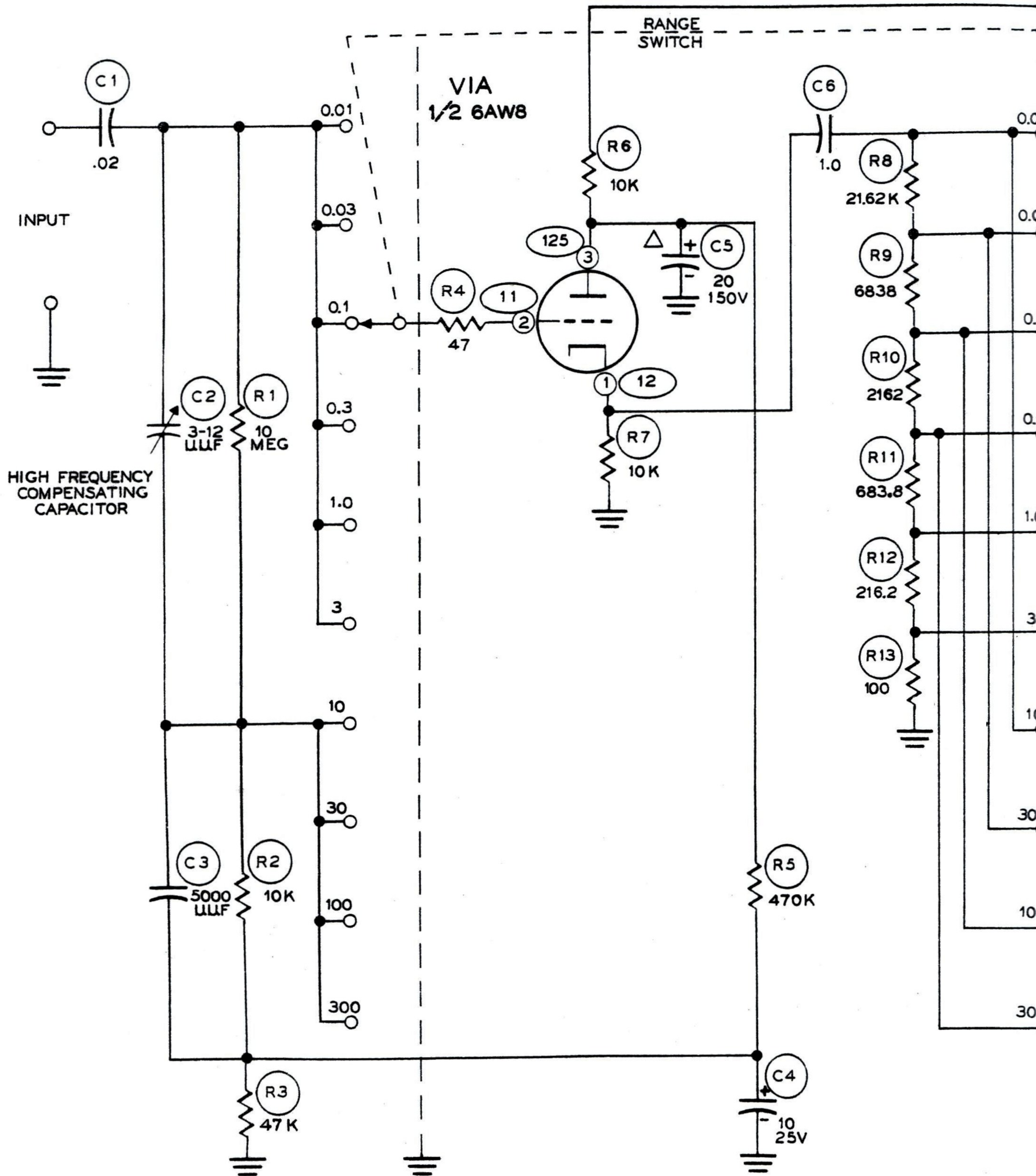

AC VACUUM TUBE VOLTMETER  
MODEL 1M-21

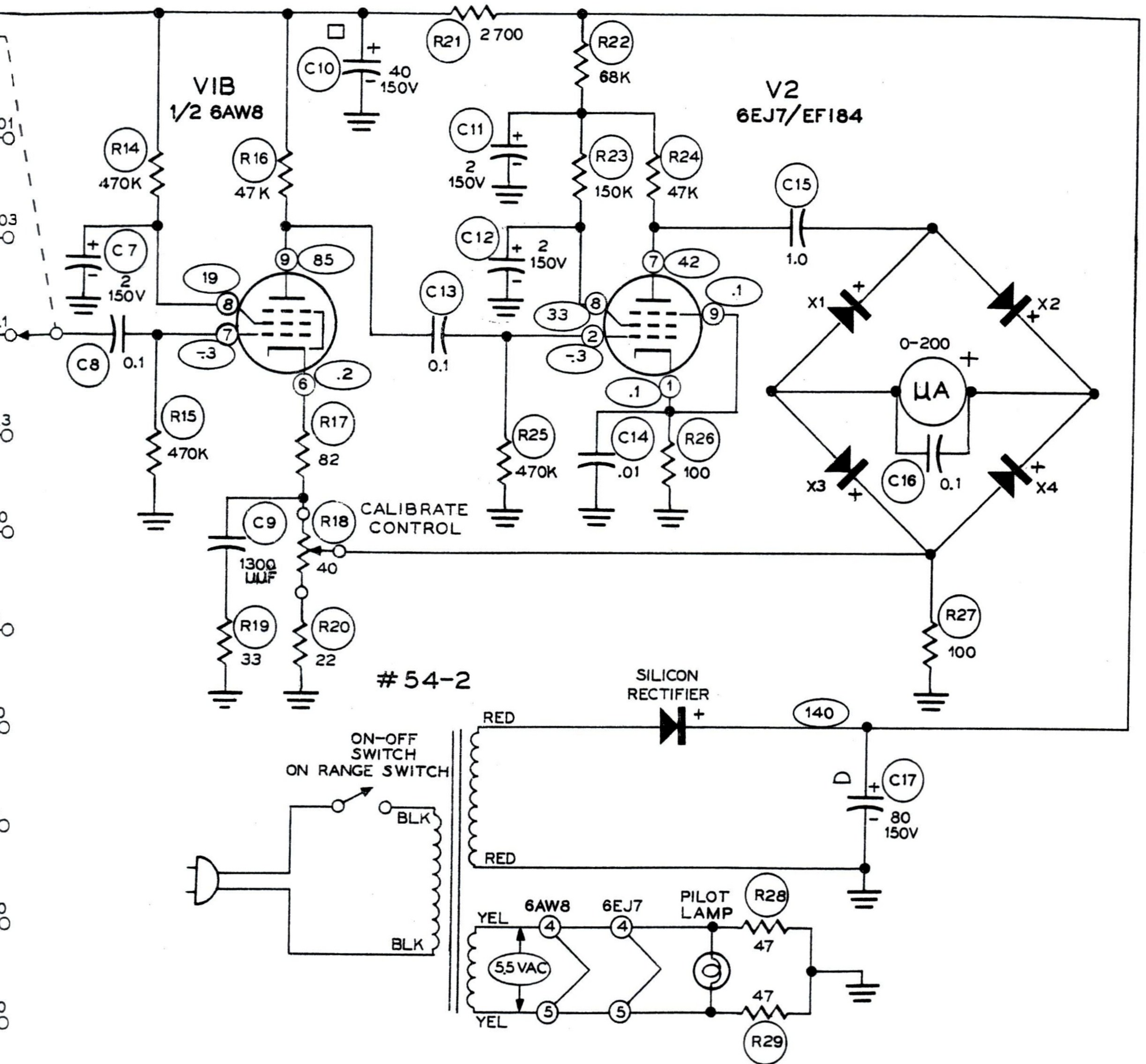

**NOTES:**

ALL RESISTORS ARE 1/2 WATT.  
 ALL RESISTOR VALUES ARE IN  $\Omega$ , 1 K = 1000  $\Omega$ , 1 MEG = 1,000,000  $\Omega$ .  
 ALL CAPACITOR VALUES ARE IN  $\mu$ fd UNLESS SHOWN OTHERWISE.

ALL VOLTAGES ARE FROM POINT INDICATED TO CHASSIS GROUND EXCEPT AC VOLTAGES ON POWER TRANSFORMER WINDINGS. READINGS WERE TAKEN WITH AN 11 MEGOHM INPUT VTVM.

VOLTAGES WERE TAKEN WITH INPUT TERMINALS SHORTED AND RANGE SWITCH IN 300 V POSITION.

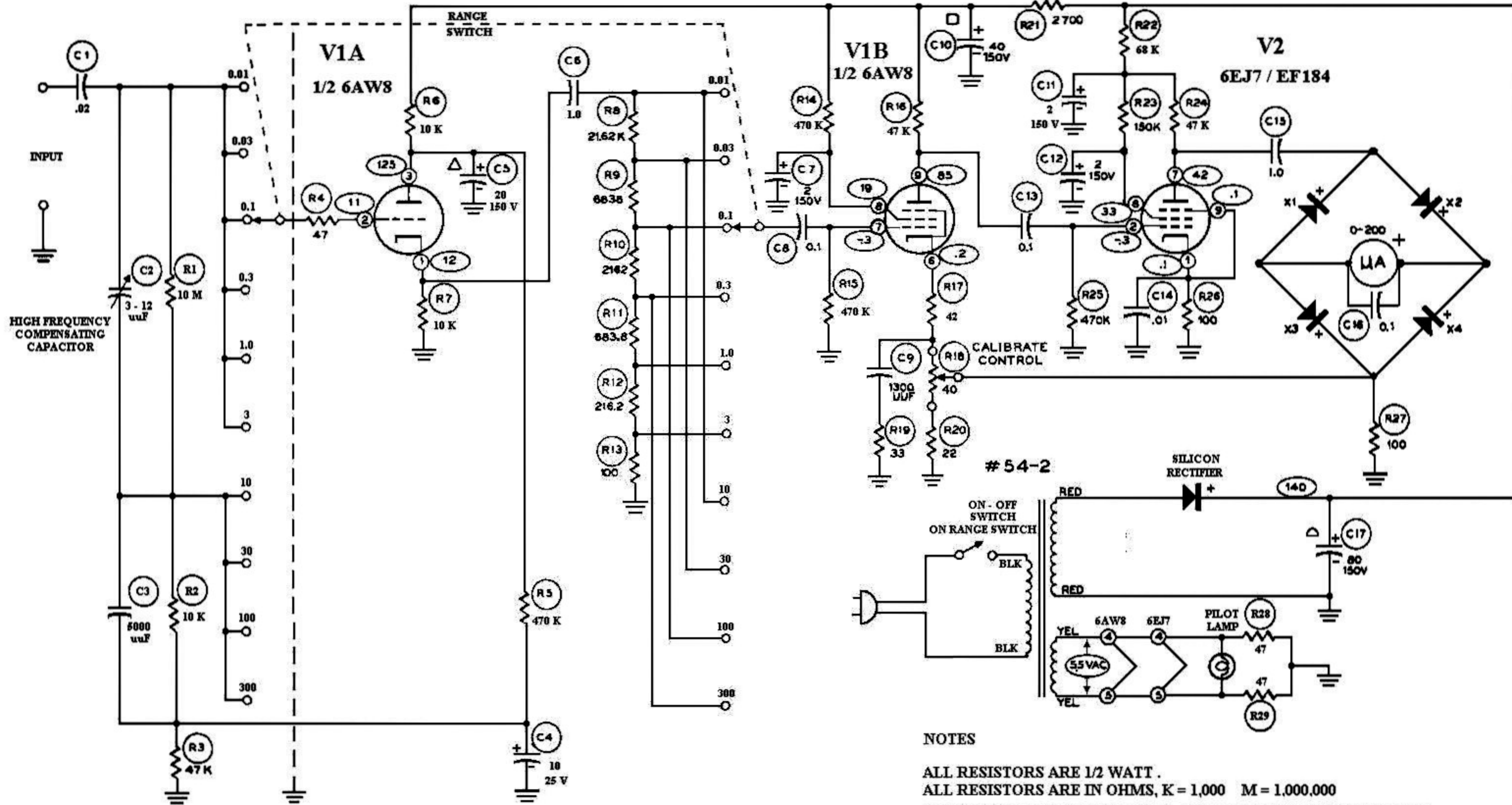

**AC VACUUM TUBE VOLTMETER  
MODEL IM - 21**

**NOTES**

ALL RESISTORS ARE 1/2 WATT .  
ALL RESISTORS ARE IN OHMS, K = 1,000 M = 1,000,000  
ALL CAPACITOR VALUES ARE IN  $\mu$ FD, UNLESS SHOWN OTHERWISE

ALL VOLTAGES ARE FROM POINT INDICATED TO CHASSIS GROUND EXCEPT  
A.C. VOLTAGES ON POWER TRANSFORMER WINDINGS. READINGS WERE TAKEN  
WITH AN 11 MEG INPUT V.T.V.M.

VOLTAGES WERE TAKEN WITH INPUT TERMINALS SHORTED AND RANGE  
SWITCH IN 300 VOLT POSITION

IDEAL PRECISION METER CO., INC.

R.M.S. VOLTS



DECIBELS  
1 MILLIWATT 600 OHMS

*Heathkit*

THE HEATH COMPANY

FS-200-A  
R = 1400 Ω  
BENTON HARBOR MICH.

AC

VTVM



MODEL

1M-21

INPUT



GROUND





R.M.S. VOLTS

DECIBELS

1 MILLIWATT 600 OHMS

*Heathkit*

THE HEATH COMPANY

10-33024  
P-1405 G  
BENTON HARTSCOCK, MICH.

AC

1.0

3.0

10

VTVM

0.3

0

+10

+20

+30

0.1

-20

+

30

40

100

.03

-30

+

50

300

.01

OFF

MODEL

1M-21

INPUT

GROUND