

FRASER ELECTRONICS

EDMONTON CANADA



AUDIO CHASE
SENSITIVITY



AUDIO

TRIGGER
SOURCE



AUTO

AUTO CHASE
RATE



INVERT



MODE

SHIMMER



REVERSE



MODEL
R3
PROGRAMMED
LIGHTING
CONTROLLER

BRIGHT



DIM

POWER



FRASER ELECTRONICS

ANNOUNCES THE R3 PROGRAMMED LIGHTING CONTROLLER

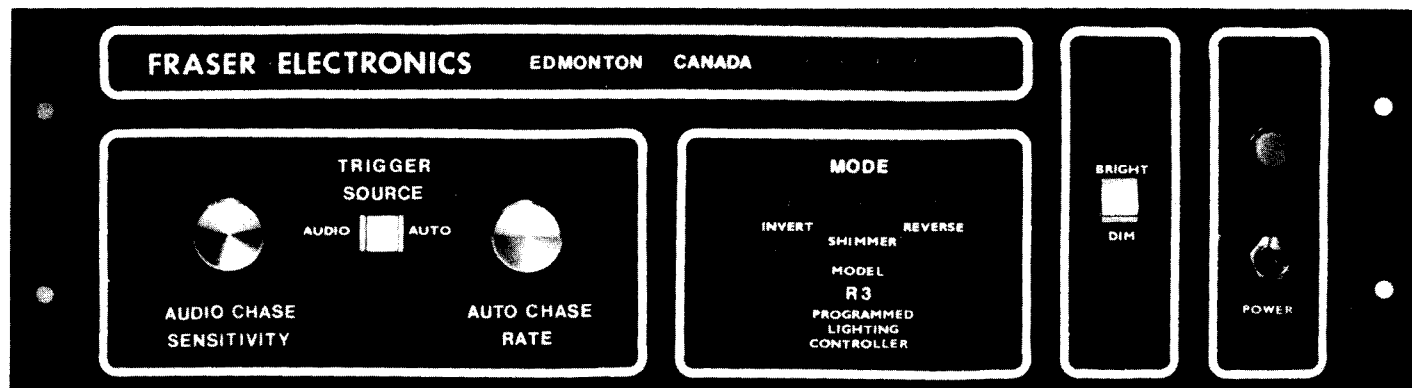

The new R3 synchronizes your lights to the rhythm of the music using the latest digital circuits.

FEATURES:

- Adjustable audio sensitivity
- Adjustable automatic sequence rate
- 16 chase effects stored in a PROM computer type memory
- Automatic effect change after every 512 chase steps
- Three modifiers including invert, shimmer and reverse direction
- Automatic modifier change after every 128 chase steps
- 3 LEDs to indicate modifier combination selected
- 4 LEDs to indicate the output
- Bright/Dim switch
- 1800 watts load capacity — more available on request
- Matrix output available to permit operation on 2 axis — suitable for starburst effects
- Audio input sensitivity — .1 watts to 200 watts applied at input jack
- Audio input impedance over 1000 ohms
- Audio input — standard 1/4" phone jack isolated from chassis and internal circuitry
- All triacs opto-coupled from drive circuits
- Dimensions: 48.25 x 30 x 13.33 cm (Standard 5¼" x 19" rack mount)

May 20/79

Daniel Frown

R3 CONTROLLER

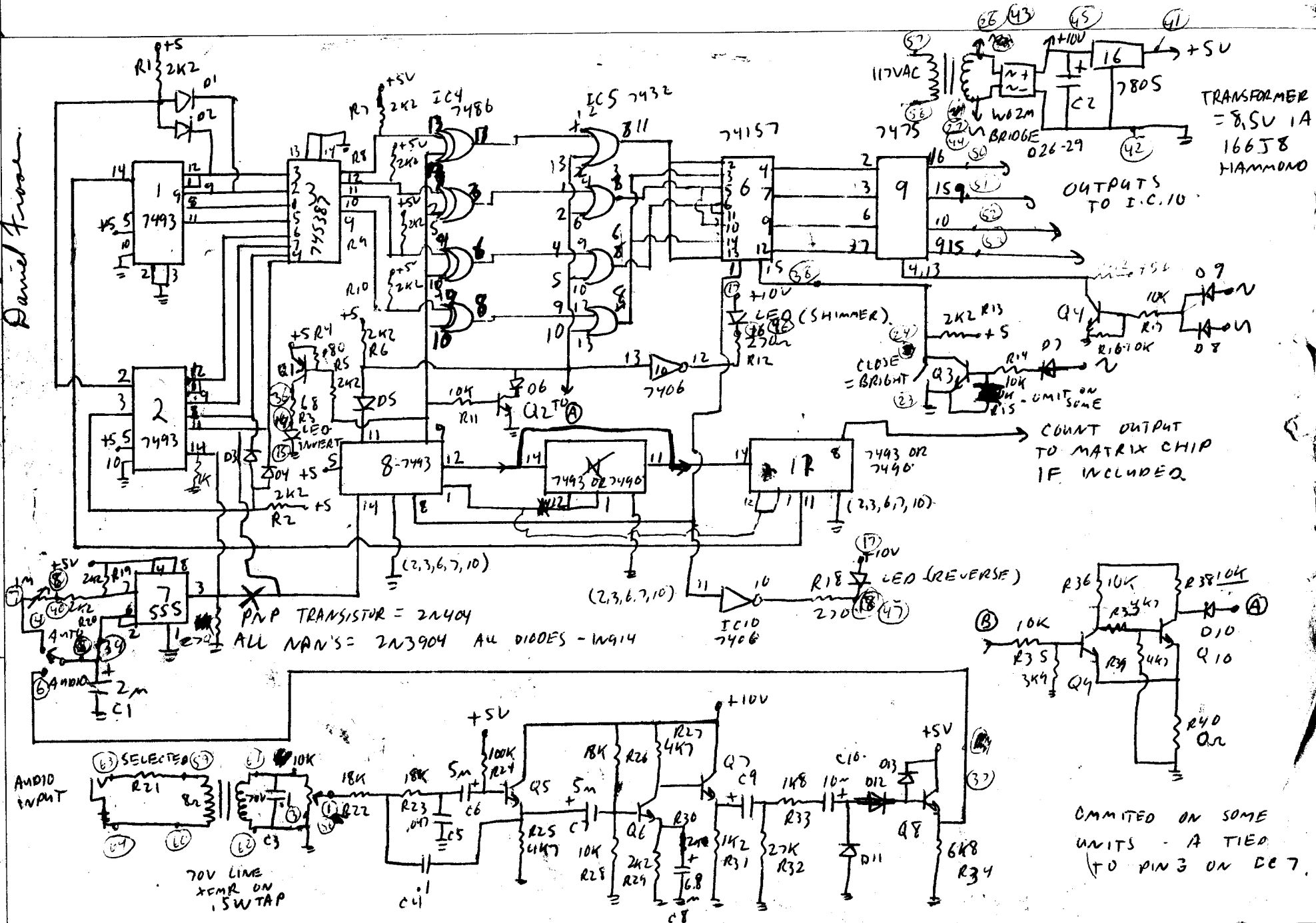

TRANSFORMER
= 8.5V 1A
166J8
HAMMOND

OUTPUTS
TO I.C.10

COUNT OUTPUT
TO MATRIX CHIP
IF INCLUDED

PNP TRANSISTOR = 2N404
ALL NPN'S = 2N3904 ALL DIODES - 1N914

OMMITTED ON SOME
UNITS - A TIED
TO PIN 3 ON IC7.

R30 CHANGE TO
220 ON
SOME UNITS.

May 20/79

MATRIX SECTION

FROM IC 12 PIN 8

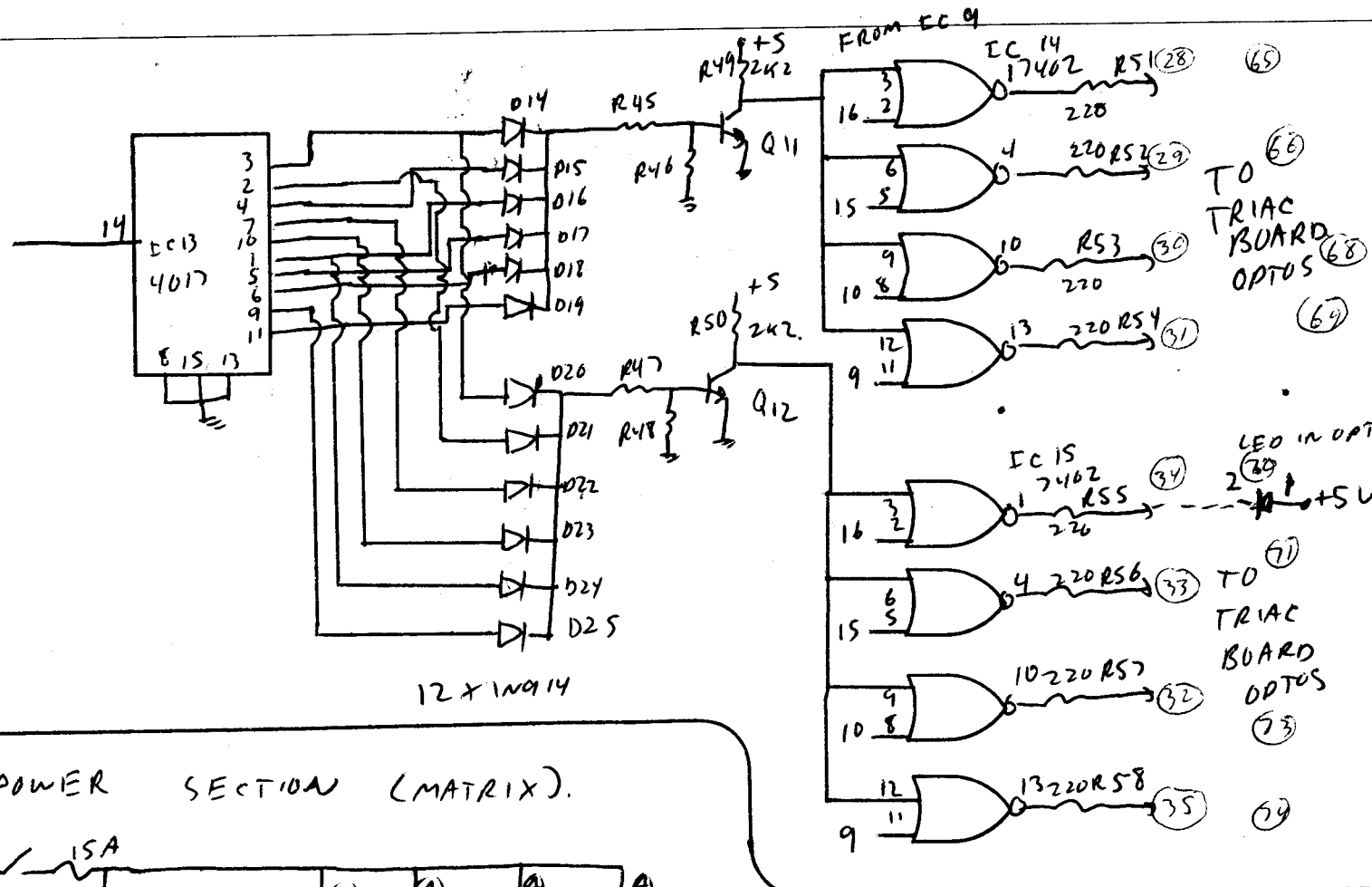

POWER SECTION (MATRIX).

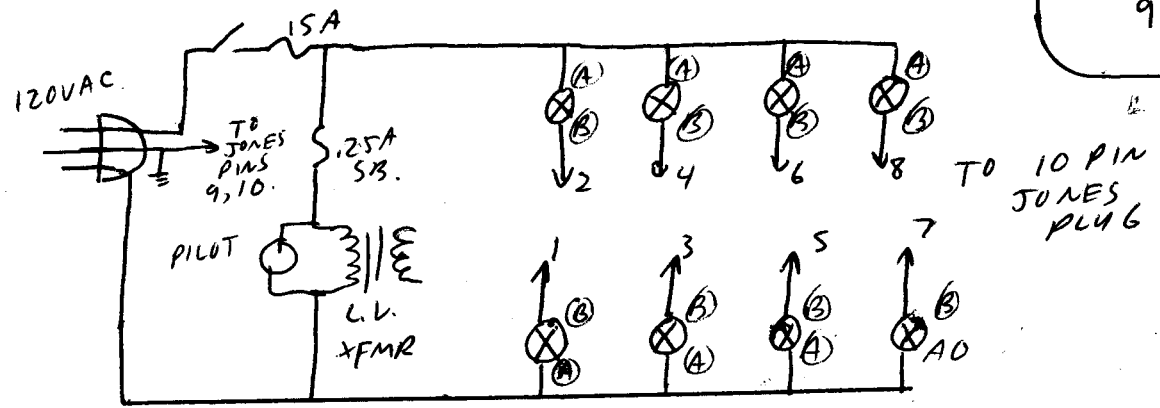

R3 Controller

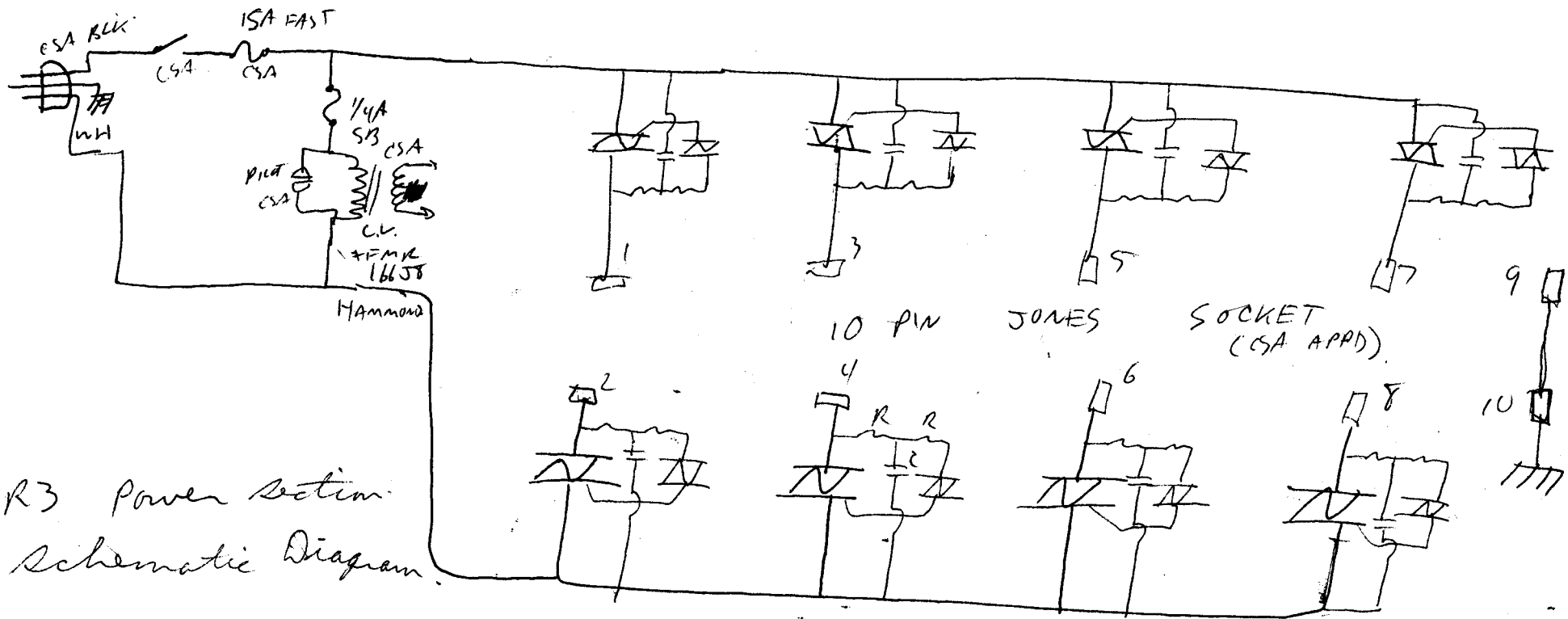

R3 Power Section
Schematic Diagram

June 8/79
D. F. [unclear]

ALL 16 Resistors = 220 Ω 270 Ω 1/2 W
 all 8 Capacitors = .01 μ F 250V MIN.
 all Diodes = GE SC142B or equal (UL)
 all Optos = Motorola MOC3010 or MOC3011 (UL APPROV.)

R3
MEMORY

25
of
these

FRASER flow.

WORD NO.	OUTPUTS				REMARKS
	04	03	02	01	
0	0	1			7
1	1	0			B
2			0		D
3				0	E
4	0				7
5		0			B
* 6			0		D
7				0	E
8	0				7
9		0			B
10			0		D
11				0	E
12	0				7
13		0			B
14			0		D
15				0	E
16	0	0			3
17		0	0		9
18			0	0	C
19	0	1		0	6
20	0	0			3
21		0			9
22			0	0	C
23	0			0	6
24	0	0			3
25		0	0		9
26			0	0	C
27	0			0	6
28	0	0			3
29		0	0		9
30			0	0	C
31	0			0	6
32	0				7
33		0			B
34			0		D
35				0	E
36	0				7
37		0			B
38			0		D
39				0	E
40			0	0	E
41			0		D
42		0			B
43	0				7
44				0	E
45			0		D
46	0	0			B
47	0				7
48	C				B
49		0			D
50			0		E
51				0	E
52		0	0		D
53	C	0			B
54	C				G
55		0			G
56			0		D
57				C	E
58		0	0		D
59	C	0			B
60	C				B
61		0			B

WORD NO.	OUTPUTS				REMARKS
	04	03	02	01	
64	0	0			3
65	1	1	0	0	C
66	0	0			3
67		1	0	0	C
68	0	0			3
69		1	0	0	C
70	0	0			C
71		1	0	0	C
72	0	0			3
73	0	0			3
74			0	0	C
75		0			C
76	0	0			3
77	0	0			3
78			0	0	C
79			0	0	C
80				0	E
81			0		D
82		0			B
83	0				7
84	1			0	E
85			0		D
86		0			B
87	0				7
88				0	E
89			0		D
90		0			B
91	C				7
92	0				7
93		0			B
94			0		D
95				0	E
96	0				7
97		0			B
98			0		D
99			0		E
100			0		D
101		0			B
102	C	1			7
103		0			B
104			0		D
105				0	E
106			0		D
107		0			B
108	0				7
109		0			B
110			0		D
111		1		0	E
112	0	0			3
113		0	0		9
114			0	0	C
115	0			0	6
116			0	0	C
117		0			9
118	0	0			3
119		0			9
120			0	0	C
121	0				6
122			0	0	C
123		0	0		9
124	0	0			3
125		1	0		9

WORD NO.	OUTPUTS				REMARKS
	04	03	02	01	
128	0				7
129		0			B
130			0		D
131				0	E
132				0	E
133			0		D
134			0		D
135		0			B
136		0			B
137	0				7
138	0				7
139		0			B
140			0		D
141				0	E
142			0		D
143		0			B
144	0	0	1	0	2
145	0	0	1	0	3
146	0	1	1	0	6
147	1	0	0	1	9
148	1	1	0	0	C
149	1	1	1	0	E
150	0	0	1	0	2
151	0	1	0	1	S
152	1	0	0	0	B
153	1	0	1	1	B
154	1	1	1	0	E
155	0	0	0	1	1
156	0	1	0	0	4
157	0	1	1	1	7
158	1	0	1	0	A
159	1	0	0	1	D
160		0			B
161			0		D
162		0			B
163	0				7
164		0			B
165			0		D
166				0	E
167			0		D
168		0			B
169			0		D
170		0			B
171	0				7
172		0			B
173			0		D
174				0	E
175			0		D
176	0	0			3
177		0			9
178			0	0	C
179	0			0	6
180	0	0			3
181		0			9
182			0	0	C
183	0			0	6
184	0	0			3
185		0			9
186			0	0	C
* 187		0	0		9
188	0	0			9
189		0			9

WORD NO.	OUTPUTS				REMARKS
	04	03	02	01	
192	0				7
193		0			B
194			0		D
195				0	E
196	0				7
197		0			B
198			0		D
199				0	E
200	0				7
201		0			B
202			0		D
203				0	E
204	0				7
205		0			B
206			0		D
207		0			B
208	0	1	0		S
209	1	0	1	0	S
210	0	1	0		S
211	1	0		0	S
212	0	1	0		S
213	1	0		0	A
214	0	1	0		S
215	0	1	0		S
216	1	0		0	A
217	1	0		0	A
218	0	1	0		S
219	0	1	0		S
220	1	0		0	A
221	1	0		0	A
222	0	1	0		S
223	1	0		0	A
224	0	0			3
225		0	0		9
226		1	0	0	C
227	0			0	6
228			0	0	C
229			0	0	C
230		0	0		9
231		0	0		9
232	0	0			9
233	1	0		0	9
234			0	0	C
235	0			0	6
236			0	0	C
237			0	0	C
238		0	0		9
239	0	0			9
240	0				7
241		0			B
242	0				7
243		0			B
244			0		D
245		0			7
246	0				7
247		0			B
248			0		D
249				0	E
250			0		D
251		0			B
252	0				7
253		0			B
254		1			D

\$500

D
Ø

Next Time Please check
Truth Table

A Note for the Professional Technician Installing this unit.

When installing these units care should be taken to allow unrestricted air flow around the cabinet if the loading exceeds 2500Watts total. If it is installed in an enclosed cabinet, a fan should be provided to allow sufficient cooling.

When inserting the AMP pins into the connector they should be inserted as far as they can go until they click into place. After the socket pins are in place, the pin should be flared slightly with the prong on a pair of needle nose pliers or with a small punch. If this is not done the connector will be extremely difficult to fit into place. Also, if more than 5 Amps will be flowing through any pin, the connection should be soldered as well as crimped or the connector will run warm.

Note that any short circuit in the load will instantly blow a triac if power is connected and shorted triacs are not covered under the warranty except when the lights are also purchased and installed by the dealer selling the controller.

While the power switch is a UL and CSA approved 20Amp per side type, its life can be extended indefinitely if the lamps are switched off by the "LIGHTS ON" switch before the power is switched off. Conversely, when switching on, switch life will be improved if the lamp load is turned off with the lights on switch before switching on. After the power switch is turned on and the controller is running, the load can be engaged with the lights on switch. The lights on switch operates at logic level and may be used as often as necessary with no detriment to anything.

The Bright/Dim switch comes jumpered out on all US models, and this jumper must be removed if you want the dim function to work. The reason that this is done, is because if the dim is engaged with transformer operated loads such as "RAIN LIGHTS" or NEON, the transformers in them will be destroyed and the controller may be damaged. The reason for this is that on dim, DC is applied to the load which cannot be used by transformers. The jumper prevents accidental damage from the use of this switch. If ordinary incandescent lamps are used, however, it is perfectly safe to use the dim function as long as none of the lamps are transformer operated.

To ease in service, the schematic diagram is tucked in under the main printed circuit board.

The input connections for the power are industry standard color code. The BLACK and RED are the HOT lines and should be 110Volts above the Neutral which is WHITE. The voltage between the Red and Black may be 180' out of phase giving a reading of as high as 240V. The GREEN of course is your chassis ground. Under no circumstances should the unit be connected to two legs of a three phase system. If this is done, it will still function, but the zero crossing timing will be at the wrong time for two channels, and there will be a large amount of electrical noise induced into the sound system. If the input power is three phase, both the red and black must be on the same leg.

If there are any further question, I may be contacted through the dealer where this unit was purchased.

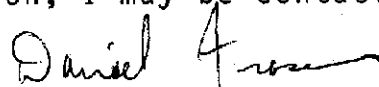

Daniel Fraser

Aug. 18/1980



FRASER ELECTRONICS
MEMORY LIGHTING CONTROLLER

● ● ● ●

MODEL RJ

BASS

LO-MID

HI-MID

TREBLE

AUTO/AUDIO

S/L BOTH
CHASE

AUDIO CHASE SENSITIVITY

AUTO CHASE RATE

MANUAL

AUTOMATIC

EFFECT CHANGE RATE

MODE CHANGE RATE

BRIGHT
DIM

POWER

POWER

MADE IN CANADA

PROTOTYPE